



Tecumseh

Groupe de condensation
Code Tension : TZ

TAJN9513ZMHR-TZ

Froid Commercial Positif (MHP)

400V 3~ 50Hz / 440V 3~ 60 Hz

R452A / R404A / R448A / R449A

TAJN9513ZMHR-TZ

Conditions	Fréquence	Puissance Frigorifique Nominale		Puissance sonore ISO3745 / ISO 3743-1
		Watts	BTU/h	
EN13215 / R452A	50 Hz / 60 Hz	1618 / 1791	5519 / 6109	65 dBA
EN13215 / R404A	50 Hz / 60 Hz	1699 / 1880	5793 / 6411	65 dBA
EN13215 / R448A	50 Hz / 60 Hz	1486 / 1654	5066 / 5640	65 dBA
EN13215 / R449A	50 Hz / 60 Hz	1486 / 1655	5069 / 5643	65 dBA

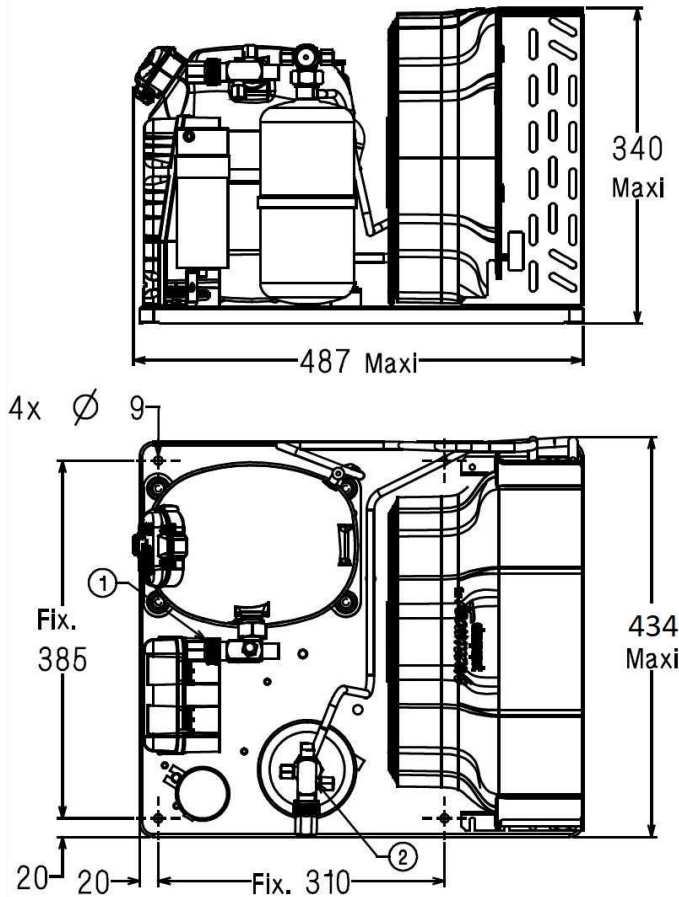

* EN13215 : T°Ambiance 32.0°C / T°Evap. -10.0°C / T°Gaz Aspirés. 20.0°C
T°Sous-refroidissement. 3.0K

Poids Net (Kg)	32.0
Type Détente	Détendeur
Débit d'air (m³/h)	900 / 900
Fiche Tec Compresseur	224JU-TZ
Type Appareillage Electrique	TRI
Intensité (Amp)	
Nominale	3 3
Maximale	4.1 4.1
Démarrage	16.9 17.5
Ventilateur	
Vitesse (tr/mn)	1200 / 1200
Puissance Mécanique (W)	30.0
Diamètre (mm)	300
Protection	Protecteur
Indice de Protection (IP)	IP54
Condenseur	300/3900
Réservoir de liquide	
Volume (L)	1.5
PMS (Bars)	32.0
Conduite Aspiration	
Composant	Vanne Orientable
Diamètre extérieur	15.9 (5/8")
Type de Connexion	à Braser
Conduite Départ Liquide	
Composant	Vanne Orientable
Pour Tube Diam Ext	9.5 (3/8")
Type de Connexion	à Braser
ID Raccord Client	VR
Grille	maille < à 8mm

Nota : Tecumseh se réserve le droit de modifier les informations contenues dans ce document sans préavis.



Tecumseh

TAJN9513ZMHR-TZ	Tension TZ : 400V 3~ 50Hz / 440V 3~ 60 Hz
------------------------	--

Les performances sont données dans les conditions EN13215 :	Gaz aspirés :	20.0 °C
Condition Dew	Sous refroidissement :	3.0 K
The performance data are in EN13215 conditions :	Return gas :	20.0 °C
Dew Condition	Subcooling :	3.0 K

© 2023 Tecumseh Products Company
All rights reserved

50 Hz R452A

N°6348

5 T ambience	6 T évaporation	(°C)	-25	-20	-15	-10	-5	0	5	10	15
25	1 P frigorifique	(Watt)	956	1218	1509	1824	2157	2502	2852	3201	3547
	2 P absorbée	(W)	675	766	866	976	1097	1229	1374	1532	1706
	3 I absorbée	(A)	1.62	1.75	1.88	2.03	2.20	2.38	2.58	2.80	3.04
	4 Tc	(°C)	31.4	34.2	37.0	40.0	43.1	46.3	49.6	53.0	56.5
32	1 P frigorifique	(Watt)	809	1058	1329	1618	1921	2232	2546	2861	3176
	2 P absorbée	(W)	688	783	889	1006	1133	1273	1426	1592	1773
	3 I absorbée	(A)	1.61	1.75	1.90	2.07	2.25	2.44	2.66	2.89	3.14
	4 Tc	(°C)	37.1	39.7	42.4	45.2	48.0	51.0	54.2	57.4	60.7
43	1 P frigorifique	(Watt)		805	1046	1296	1553	1813			
	2 P absorbée	(W)		806	920	1047	1186	1338			
	3 I absorbée	(A)		1.74	1.92	2.12	2.32	2.54			
	4 Tc	(°C)		48.4	50.8	53.3	55.9	58.7			

60 Hz R452A

N°6348

5 T ambience	6 T évaporation	(°C)	-25	-20	-15	-10	-5	0	5	10	15
25	1 P frigorifique	(Watt)	1103	1383	1687	2009	2342	2682	3027	3377	3740
	2 P absorbée	(W)	805	933	1074	1228	1394	1574	1768	1976	2197
	3 I absorbée	(A)	1.62	1.77	1.94	2.13	2.34	2.57	2.82	3.09	3.37
	4 Tc	(°C)	32.9	36.5	40.0	43.5	47.0	50.4	53.7	57.0	60.3
32	1 P frigorifique	(Watt)	936	1206	1493	1791	2098	2410	2727	3055	
	2 P absorbée	(W)	801	939	1089	1252	1428	1616	1818	2032	
	3 I absorbée	(A)	1.61	1.77	1.96	2.16	2.38	2.62	2.87	3.15	
	4 Tc	(°C)	38.3	41.6	44.9	48.2	51.4	54.6	57.7	60.7	
43	1 P frigorifique	(Watt)		928	1187	1451	1717				
	2 P absorbée	(W)		924	1093	1273	1466				
	3 I absorbée	(A)		1.75	1.95	2.18	2.42				
	4 Tc	(°C)		49.9	52.8	55.7	58.5				

1 = cooling capacity 2 = power input 3 = current 4 = condensing temperature 5 = ambient temperature 6 = evaporating temperature

Nota : Tecumseh se réserve le droit de modifier les informations contenues dans ce document sans préavis.

Note : Tecumseh reserves the right to change information contained in this document without notification.



Tecumseh

TAJN9513ZMHR-TZ	Tension TZ : 400V 3~ 50Hz / 440V 3~ 60 Hz
------------------------	--

Les performances sont données dans les conditions EN13215 :	Gaz aspirés :	20.0 °C
Condition Dew	Sous refroidissement :	3.0 K
The performance data are in EN13215 conditions :	Return gas :	20.0 °C
Dew Condition	Subcooling :	3.0 K

50 Hz R404A											
											N°5069
5 T ambience	6 T évaporation	(°C)	-25	-20	-15	-10	-5	0	5	10	15
25	1 P frigorifique	(Watt)	1043	1309	1601	1915	2241	2573	2903	3223	3528
	2 P absorbée	(W)	713	806	908	1019	1140	1271	1412	1566	1733
	3 I absorbée	(A)	1.71	1.83	1.97	2.12	2.28	2.46	2.65	2.86	3.09
	4 Tc	(°C)	34.2	36.9	39.8	42.6	45.6	48.7	51.8	55.0	58.3
32	1 P frigorifique	(Watt)	887	1140	1412	1699	1994	2290	2583	2866	3138
	2 P absorbée	(W)	729	827	935	1052	1179	1317	1467	1628	1802
	3 I absorbée	(A)	1.70	1.84	1.99	2.16	2.33	2.52	2.73	2.95	3.19
	4 Tc	(°C)	39.8	42.3	44.9	47.6	50.4	53.2	56.2	59.2	62.3
43	1 P frigorifique	(Watt)	641	875	1116	1362	1610	1854			
	2 P absorbée	(W)	752	856	972	1099	1238	1387			
	3 I absorbée	(A)	1.68	1.85	2.03	2.22	2.41	2.62			
	4 Tc	(°C)	48.5	50.7	53.0	55.4	57.8	60.4			

60 Hz R404A											
											N°5069
5 T ambience	6 T évaporation	(°C)	-25	-20	-15	-10	-5	0	5	10	15
25	1 P frigorifique	(Watt)	1204	1487	1791	2107	2430	2752	3070	3384	3697
	2 P absorbée	(W)	853	985	1129	1284	1451	1630	1820	2021	2234
	3 I absorbée	(A)	1.70	1.86	2.03	2.22	2.43	2.66	2.90	3.16	3.43
	4 Tc	(°C)	35.7	39.2	42.6	46.0	49.3	52.6	55.7	58.8	61.9
32	1 P frigorifique	(Watt)	1029	1301	1587	1880	2175	2468	2758	3046	
	2 P absorbée	(W)	855	996	1149	1313	1489	1675	1872	2080	
	3 I absorbée	(A)	1.70	1.87	2.05	2.26	2.47	2.71	2.96	3.22	
	4 Tc	(°C)	40.9	44.2	47.4	50.5	53.6	56.5	59.5	62.3	
43	1 P frigorifique	(Watt)		1009	1268	1525	1779	2029			
	2 P absorbée	(W)		990	1161	1343	1534	1736			
	3 I absorbée	(A)		1.86	2.06	2.29	2.52	2.77			
	4 Tc	(°C)		52.1	54.9	57.6	60.2	62.8			

1 = cooling capacity 2 = power input 3 = current 4 = condensing temperature 5 = ambient temperature 6 = evaporating temperature

Nota : Tecumseh se réserve le droit de modifier les informations contenues dans ce document sans préavis.
 Note : Tecumseh reserves the right to change information contained in this document without notification.

© 2023 Tecumseh Products Company
All rights reserved



Tecumseh

TAJN9513ZMHR-TZ	Tension TZ : 400V 3~ 50Hz / 440V 3~ 60 Hz
------------------------	--

Les performances sont données dans les conditions EN13215 :	Gaz aspirés :	20.0 °C
Condition Dew	Sous refroidissement :	3.0 K
The performance data are in EN13215 conditions :	Return gas :	20.0 °C
Dew Condition	Subcooling :	3.0 K

50 Hz R448A (*)											
											N°6984
5 T ambience	6 T évaporation	(°C)	-25	-20	-15	-10	-5	0	5	10	15
25	1 P frigorifique	(Watt)		1062	1349	1665	2009	2378	2768	3177	3603
	2 P absorbée	(W)		725	822	930	1051	1184	1332	1495	1674
	3 I absorbée	(A)		1.65	1.79	1.94	2.11	2.29	2.50	2.73	2.99
	4 Tc	(°C)		34.5	37.5	40.5	43.6	46.8	50.1	53.5	56.9
32	1 P frigorifique	(Watt)			1191	1486	1805	2146	2507		
	2 P absorbée	(W)			845	960	1088	1230	1387		
	3 I absorbée	(A)			1.81	1.98	2.16	2.36	2.59		
	4 Tc	(°C)			42.8	45.6	48.5	51.5	54.6		
43	1 P frigorifique	(Watt)				1209	1491				
	2 P absorbée	(W)				1003	1144				
	3 I absorbée	(A)				2.03	2.24				
	4 Tc	(°C)				53.8	56.4				

60 Hz R448A (*)											
											N°6984
5 T ambience	6 T évaporation	(°C)	-25	-20	-15	-10	-5	0	5	10	15
25	1 P frigorifique	(Watt)		1206	1511	1842	2197	2575	2977		
	2 P absorbée	(W)		882	1019	1170	1337	1520	1718		
	3 I absorbée	(A)		1.68	1.85	2.04	2.25	2.48	2.74		
	4 Tc	(°C)		36.9	40.4	44.0	47.4	50.8	54.2		
32	1 P frigorifique	(Watt)			1341	1654	1988	2344			
	2 P absorbée	(W)			1034	1195	1372	1564			
	3 I absorbée	(A)			1.86	2.06	2.29	2.53			
	4 Tc	(°C)			45.4	48.7	51.9	55.0			
43	1 P frigorifique	(Watt)				1365					
	2 P absorbée	(W)				1215					
	3 I absorbée	(A)				2.08					
	4 Tc	(°C)				56.2					

1 = cooling capacity 2 = power input 3 = current 4 = condensing temperature 5 = ambient temperature 6 = evaporating temperature

(*) Veuillez vous référer strictement aux Recommandations d'Utilisation et Bulletins Marketing Tecumseh du fait de la température de refoulement élevée pour les applications LBP.
 (*) Due to very high discharge temperature especially on LBP conditions, please strictly refer to Tecumseh Guidelines & Marketing Bulletin when using this refrigerant.

Nota : Tecumseh se réserve le droit de modifier les informations contenues dans ce document sans préavis.

Note : Tecumseh reserves the right to change information contained in this document without notification.

© 2023 Tecumseh Products Company
All rights reserved



Tecumseh

TAJN9513ZMHR-TZ	Tension TZ : 400V 3~ 50Hz / 440V 3~ 60 Hz
------------------------	--

Les performances sont données dans les conditions EN13215 :	Gaz aspirés :	20.0 °C
Condition Dew	Sous refroidissement :	3.0 K
The performance data are in EN13215 conditions :	Return gas :	20.0 °C
Dew Condition	Subcooling :	3.0 K

© 2023 Tecumseh Products Company
All rights reserved

50 Hz R449A (*)

N°6226

5 T ambience	6 T évaporation	(°C)	-25	-20	-15	-10	-5	0	5	10	15
25	1 P frigorifique	(Watt)		1063	1350	1666	2010	2379	2770	3179	3604
	2 P absorbée	(W)		725	822	930	1051	1184	1332	1495	1674
	3 I absorbée	(A)		1.65	1.79	1.94	2.11	2.29	2.50	2.73	2.99
	4 Tc	(°C)		34.6	37.5	40.5	43.5	46.7	50.0	53.4	56.9
32	1 P frigorifique	(Watt)			1191	1486	1806	2147	2508		
	2 P absorbée	(W)			845	960	1088	1230	1387		
	3 I absorbée	(A)			1.81	1.98	2.16	2.36	2.59		
	4 Tc	(°C)			42.8	45.6	48.5	51.5	54.6		
43	1 P frigorifique	(Watt)				1210	1492				
	2 P absorbée	(W)				1003	1144				
	3 I absorbée	(A)				2.03	2.24				
	4 Tc	(°C)				53.8	56.3				

60 Hz R449A (*)

N°6226

5 T ambience	6 T évaporation	(°C)	-25	-20	-15	-10	-5	0	5	10	15
25	1 P frigorifique	(Watt)		1206	1512	1843	2198	2577	2978		
	2 P absorbée	(W)		882	1019	1170	1337	1520	1718		
	3 I absorbée	(A)		1.68	1.85	2.04	2.25	2.48	2.74		
	4 Tc	(°C)		36.9	40.4	44.0	47.4	50.8	54.1		
32	1 P frigorifique	(Watt)			1342	1655	1989	2345			
	2 P absorbée	(W)			1034	1195	1372	1564			
	3 I absorbée	(A)			1.86	2.06	2.29	2.53			
	4 Tc	(°C)			45.4	48.6	51.8	55.0			
43	1 P frigorifique	(Watt)				1366					
	2 P absorbée	(W)				1215					
	3 I absorbée	(A)				2.08					
	4 Tc	(°C)				56.1					

1 = cooling capacity 2 = power input 3 = current 4 = condensing temperature 5 = ambient temperature 6 = evaporating temperature

(*) Veuillez vous référer strictement aux Recommandations d'Utilisation et Bulletins Marketing Tecumseh du fait de la température de reflux élevée pour les applications LBP.

(*) Due to very high discharge temperature especially on LBP conditions, please strictly refer to Tecumseh Guidelines & Marketing Bulletin when using this refrigerant.

Nota : Tecumseh se réserve le droit de modifier les informations contenues dans ce document sans préavis.

Note : Tecumseh reserves the right to change information contained in this document without notification.