



Tecumseh

Groupe de condensation
Code Tension : FZ

AET4440ZHR-FZ

Froid Commercial Positif (HP)

220 - 240V 1~ 50 Hz

R452A / R404A / R448A / R449A

AET4440ZHR-FZ

Conditions	Fréquence	Puissance Frigorifique Nominale		Puissance sonore ISO3745 / ISO 3743-1
		Watts	BTU/h	
EN13215 / R452A	50 Hz	943	3215	65 dBA
EN13215 / R404A	50 Hz	959	3270	65 dBA
EN13215 / R448A	50 Hz	912	3112	69 dBA
EN13215 / R449A	50 Hz	913	3113	69 dBA

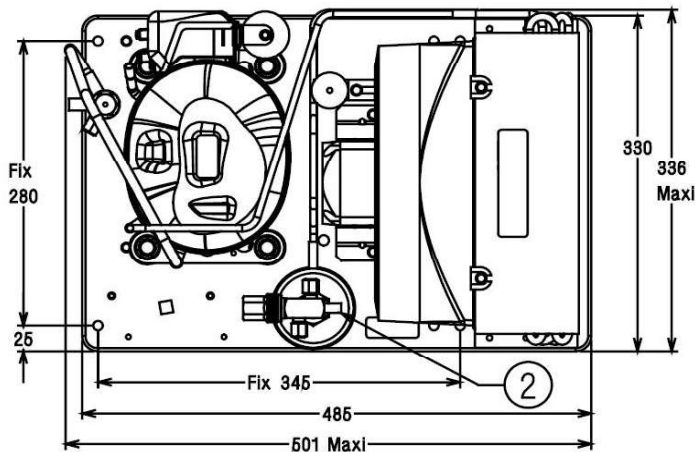
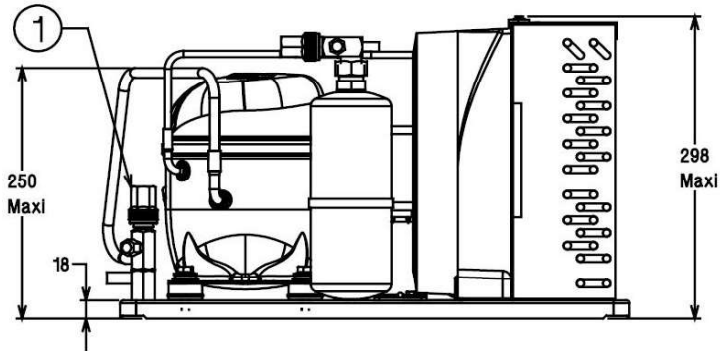

* EN13215 : T°Ambiance 32.0°C / T°Evap. 5.0°C / T°Gaz Aspirés. 20.0°C
T°Sous-refroidissement. 3.0K

Poids Net (Kg)	23.9
Type Détente	Détendeur
Débit d'air (m³/h)	500
Fiche Tec Compresseur	223ES-FZ
Type Appareillage Electrique	CSIR
Intensité (Amp)	
Nominale	3.1
Maximale	4.1
Démarrage	15.9
Ventilateur	
Vitesse (tr/mn)	1300 / 1500
Puissance Mécanique (W)	16.0
Diamètre (mm)	250
Protection	Protecteur
Indice de Protection (IP)	IP42
Condenseur	250/2300
Réservoir de liquide	
Volume (L)	0.75
PMS (Bars)	32.0
Conduite Aspiration	
Composant	Vanne de Socle
Diamètre extérieur	9.5 (3/8")
Type de Connexion	à Braser
Conduite Départ Liquide	
Composant	Vanne de Socle
Pour Tube Diam Ext	6.35 (1/4")
Type de Connexion	à Braser
ID Raccord Client	VR
Grille	maille < à 8mm

Nota : Tecumseh se réserve le droit de modifier les informations contenues dans ce document sans préavis.



Tecumseh

AET4440ZHR-FZ	Tension FZ : 220 - 240V 1~ 50 Hz
----------------------	---

Les performances sont données dans les conditions EN13215 :	Gaz aspirés :	20.0 °C
Condition Dew	Sous refroidissement :	3.0 K
The performance data are in EN13215 conditions :	Return gas :	20.0 °C
Dew Condition	Subcooling :	3.0 K

© 2020 Tecumseh Products Company
All rights reserved

50 Hz R452A											
											N°6668
5 T ambience	6 T évaporation	(°C)	-25	-20	-15	-10	-5	0	5	10	15
25	1 P frigorifique	(Watt)	327	417	520	635	763	902	1052	1212	1383
	2 P absorbée	(W)	289	314	339	365	391	418	445	474	502
	3 I absorbée	(A)	2.40	2.47	2.54	2.62	2.70	2.79	2.88	2.99	3.11
	4 Tc	(°C)	28.1	29.7	31.5	33.6	35.8	38.1	40.5	43.0	45.6
32	1 P frigorifique	(Watt)		369	464	570	685	809	943	1086	1239
	2 P absorbée	(W)		323	351	380	410	441	473	505	538
	3 I absorbée	(A)		2.47	2.56	2.66	2.75	2.86	2.97	3.10	3.23
	4 Tc	(°C)		36.1	37.8	39.6	41.7	43.8	46.1	48.4	50.8
43	1 P frigorifique	(Watt)			375	464	560	662	772	890	1018
	2 P absorbée	(W)			368	403	439	476	514	553	593
	3 I absorbée	(A)			2.59	2.71	2.84	2.98	3.11	3.26	3.41
	4 Tc	(°C)			47.6	49.2	51.0	52.8	54.8	56.9	59.0

50 Hz R404A											
											N°6654
5 T ambience	6 T évaporation	(°C)	-25	-20	-15	-10	-5	0	5	10	15
25	1 P frigorifique	(Watt)	357	447	550	666	793	930	1076	1228	1385
	2 P absorbée	(W)	302	327	353	378	403	429	455	482	509
	3 I absorbée	(A)	2.52	2.59	2.65	2.72	2.79	2.87	2.96	3.06	3.16
	4 Tc	(°C)	30.5	32.3	34.2	36.2	38.4	40.7	43.1	45.6	48.2
32	1 P frigorifique	(Watt)		397	491	596	709	831	959	1092	1229
	2 P absorbée	(W)		337	366	395	424	454	484	514	545
	3 I absorbée	(A)		2.59	2.68	2.76	2.85	2.95	3.05	3.16	3.28
	4 Tc	(°C)		38.7	40.5	42.3	44.3	46.4	48.6	51.0	53.4
43	1 P frigorifique	(Watt)			395	482	575	672	773	877	985
	2 P absorbée	(W)			385	420	455	491	527	564	601
	3 I absorbée	(A)			2.72	2.83	2.95	3.07	3.20	3.33	3.47
	4 Tc	(°C)			50.3	51.9	53.6	55.5	57.4	59.5	61.7

1 = cooling capacity 2 = power input 3 = current 4 = condensing temperature 5 = ambient temperature 6 = evaporating temperature

Nota : Tecumseh se réserve le droit de modifier les informations contenues dans ce document sans préavis.
Note : Tecumseh reserves the right to change information contained in this document without notification.



Tecumseh

AET4440ZHR-FZ	Tension FZ : 220 - 240V 1~ 50 Hz
----------------------	---

Les performances sont données dans les conditions EN13215 :	Gaz aspirés :	20.0 °C
Condition Dew	Sous refroidissement :	3.0 K
The performance data are in EN13215 conditions :	Return gas :	20.0 °C
Dew Condition	Subcooling :	3.0 K

50 Hz R448A (*)											
											N°7031
5 T ambience	6 T évaporation	(°C)	-25	-20	-15	-10	-5	0	5	10	15
25	1 P frigorifique	(Watt)	274	361	462	577	707	851	1008	1179	1361
	2 P absorbée	(W)	277	301	325	350	376	403	430	459	490
	3 I absorbée	(A)	2.27	2.34	2.41	2.49	2.58	2.67	2.77	2.88	3.01
	4 Tc	(°C)	29.1	30.6	32.3	34.1	36.1	38.3	40.7	43.3	46.1
32	1 P frigorifique	(Watt)		319	413	519	637	769	912	1068	1234
	2 P absorbée	(W)		309	337	366	396	426	458	491	526
	3 I absorbée	(A)		2.35	2.44	2.54	2.64	2.75	2.87	3.00	3.14
	4 Tc	(°C)		37.2	38.7	40.4	42.3	44.3	46.5	48.9	51.5
43	1 P frigorifique	(Watt)			335	427	529	641	763		
	2 P absorbée	(W)			353	388	425	462	501		
	3 I absorbée	(A)			2.48	2.61	2.74	2.88	3.03		
	4 Tc	(°C)			48.8	50.3	51.9	53.7	55.6		

50 Hz R449A (*)											
											N°6799
5 T ambience	6 T évaporation	(°C)	-25	-20	-15	-10	-5	0	5	10	15
25	1 P frigorifique	(Watt)	274	361	462	577	707	851	1009	1180	1361
	2 P absorbée	(W)	277	301	325	350	376	403	430	459	490
	3 I absorbée	(A)	2.27	2.34	2.41	2.49	2.58	2.67	2.77	2.88	3.01
	4 Tc	(°C)	29.2	30.7	32.3	34.2	36.2	38.3	40.7	43.3	46.0
32	1 P frigorifique	(Watt)		320	413	519	638	769	913	1069	1235
	2 P absorbée	(W)		309	337	366	396	426	458	491	526
	3 I absorbée	(A)		2.35	2.44	2.54	2.64	2.75	2.87	3.00	3.14
	4 Tc	(°C)		37.2	38.7	40.4	42.3	44.3	46.5	48.9	51.5
43	1 P frigorifique	(Watt)			335	427	529	641	763		
	2 P absorbée	(W)			353	388	425	462	501		
	3 I absorbée	(A)			2.48	2.61	2.74	2.88	3.03		
	4 Tc	(°C)			48.8	50.2	51.8	53.6	55.6		

1 = cooling capacity 2 = power input 3 = current 4 = condensing temperature 5 = ambient temperature 6 = evaporating temperature

(*) Veuillez vous référer strictement aux Recommandations d'Utilisation et Bulletins Marketing Tecumseh du fait de la température de reflux élevée pour les applications LBP.

(*) Due to very high discharge temperature especially on LBP conditions, please strictly refer to Tecumseh Guidelines & Marketing Bulletin when using this refrigerant.

Nota : Tecumseh se réserve le droit de modifier les informations contenues dans ce document sans préavis.

Note : Tecumseh reserves the right to change information contained in this document without notification.

© 2020 Tecumseh Products Company
All rights reserved