

Model

Designation	HXD55MA	220-240V/50Hz 1~	Sales code:	CDO00080
-------------	----------------	-------------------------	-------------	-----------------

Compressor design

Oil type	Mineral	Refrigerant(s)	R600a
Oil viscosity	5cSt	Displacement	5,5cm ³ / 0,34cu.in
Oil quantity	84cm ³ / 2,8fl.oz	Compressors on pallet	168
Refr. charge - tech. limit	110g / 3,9oz		
Free gas volume comp.	837cm ³ / 28,3fl.oz		
Weight	3,9kg / 8,6lbs		
Motor protection	external		
Winding resistance main	36,3Ω (at 25°C)		
Winding resistance aux	32,6Ω (at 25°C)		
Max. winding temp.	120°C / 248°F		
Max. discharge temp.	130°C / 266°F		



General - Configurations with HXD55MA

	Conf. 1	Conf. 2
Motorconfiguration	RSCR	RSIR
Power supply (nominal)	220-240V/50Hz	220-240V/50Hz
Number of phases	1	1
Voltage range	187-254V	187-254V
Approvals	VDE	VDE
Starting torque	LST	LST
Note	Electrical equipment will be pre-assembled to compressor.	

Applications with HXD55MA

	Conf. 1	Conf. 2
Refrigerant	R600a	R600a
Application	LBP+MBP	LBP+MBP
System cooling	static	static
Hot gas defrost	-/-	-/-
Long interval pull down	OK	OK

Electrical data - Configurations with HXD55MA

	Conf. 1	Conf. 2
Starting device type	PTC	PTC
Run capacitor	2μF	0μF
Start capacitor	0μF	0μF
LRA (locked rotor amps / 4s)	3,1A	3,1A
RLA (rated load amps / 1s)	0,36A	0,36A
Cut in current	7A	7A
IP class	21	21

Model

Designation	HXD55MA	220-240V/50Hz 1~	Sales code:	CDO00080
-------------	----------------	-------------------------	-------------	-----------------

Compressor dimensions

Housing	A Height	133mm / 5,24in
	B Height	134,5mm / 5,3in
	C Length shell	135mm / 5,31in
	D Length w. cover	159mm / 6,26in
	E Width	147mm / 5,79in

Connectors		Suction	Discharge	Process
		X	Y	Z
Diameter	[mm]	øi 6,1-6,3	øi 4,9-5,1	øo 5,92-6,08
(i:inside, o:outside)	[in]	øi 0,24-0,25	øi 0,19-0,2	øo 0,23-0,24
Material		copper	steel/CU	copper
Horizontal angle	±2°	0°	80°	74°
Vertical angle	±2°	79°	79°	72°
Position l/h/w	[mm]	-54/83/74	87/96/72	69/130/103
	[in]	-2,1/3,3/2,9	3,4/3,8/2,8	2,7/5,1/4,1
Straight tube l.	[mm]	14	14	14
	[in]	0,5	0,5	0,5

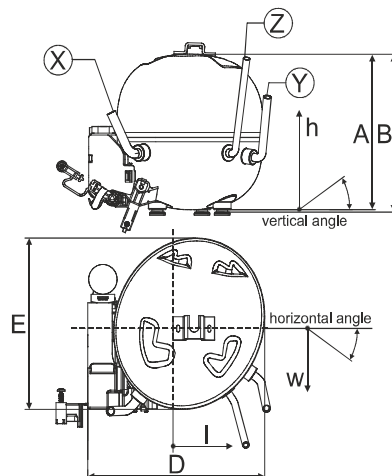

Compressor fixation

Adapter plate

Bolt joint

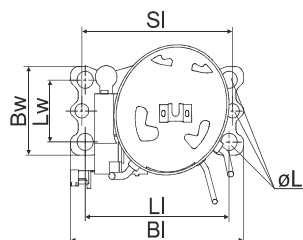

Baseplate	[mm]	[inch]
BI	204	8,03
Bw	100	3,94
Large holes		
LI	170	6,7
LW	70	2,76
SI	178	7
øL	ø 16	ø 0,63

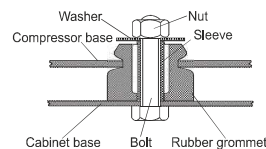

Snap-on

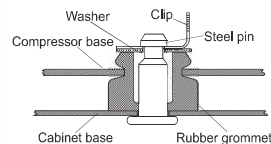

For standard mounting	one comp.	multi pack
Adapter plate	157008_	
Bolt joint M6 ø16mm	118-1917	118-1918
Bolt joint ø1/4" ø16mm	118-1946	
Snap-on ø7,3 ø16mm	118-1947	118-1919

Model

Designation **HXD55MA** **220-240V/50Hz** Conf. 1 Sales code: **CDO00080**

Configuration

Motorconfiguration RSCR
 Power supply (nominal) 220-240V/50Hz 1~
 Refrigerant R600a
 Application LBP+MBP
 Voltage range 187-254V
 Starting torque LST
 Approvals VDE

Electrical accessories / wiring diagram

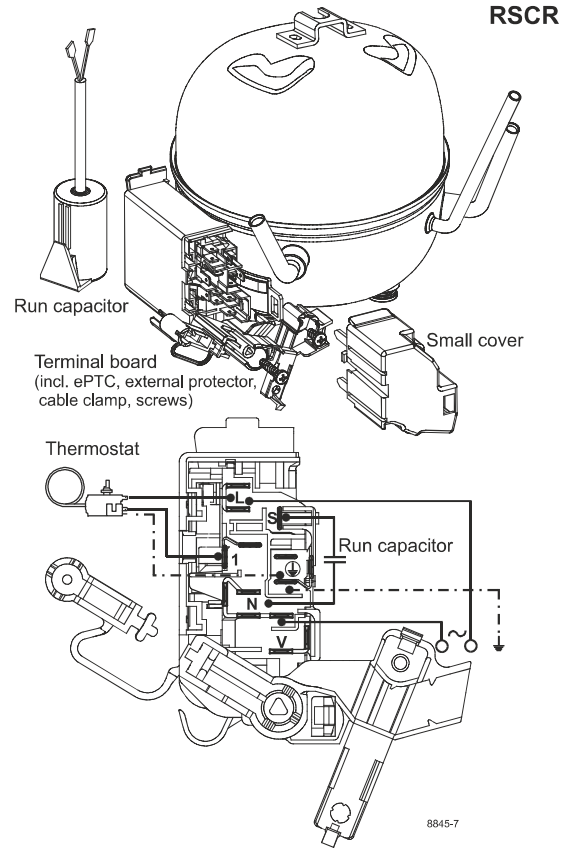

Ambient temperatures / system cooling

Ambient temperature min.: 10°C / 50°F
 Ambient temperature max.: 43°C / 110°F

System cooling			
T ambient	LBP	MBP	HBP
32°C / 90°F	static	static	n/a
38°C / 100°F	static	static	n/a
43°C / 110°F	static	static	n/a

Operation pressure range

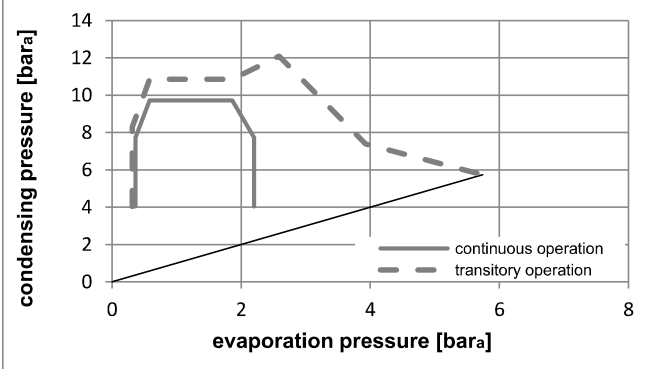
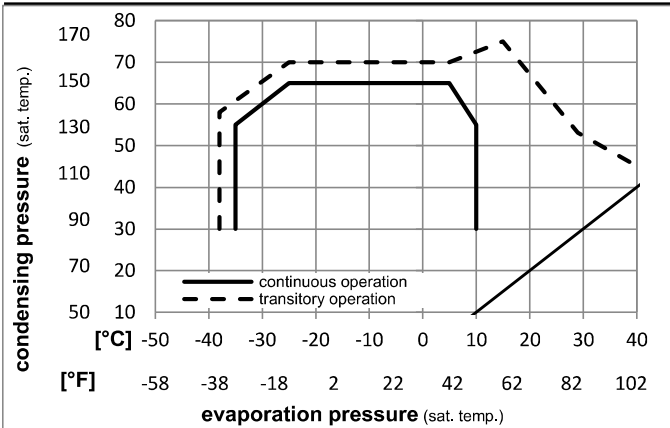

Components (will be pre-assembled)

- . terminal board (ePTC,4.8mm) BX E4
- . motor protector BDG AE 23 FLS 17 x E4
- . run capacitor (2µF, 4.8mm) cap. 2µF
- . cover terminal board 160943_

Model

Designation	HXD55MA	220-240V/50Hz	Conf. 1	Sales code:	CDO00080
-------------	----------------	----------------------	----------------	-------------	-----------------

Optimization + standard conditions

220-240V/50Hz 1~, RSCR, static, VDE

	Evaporating pressure (saturation temperature)				Cooling capacity						Power consumption			ASHRAE LBP
	pe	pc	RGT	Tliq	[W]	[Btu/h]	[kcal/h]	COP [W/W]	EER [Btu/Wh]	[kcal/Wh]	P1 [W]	I [A]	Ref. mass flow ṁ [kg/h]	
[°C]	-23,3	54,4	32,2	32,2	96,7	330	83,2	1,55	5,29	1,33	62,4	0,36	1,04	ASHRAE LBP
[°F]	-10	130	90	90										
[°C]	-25	55	32	55	72,6	248	62,5	1,21	4,12	1,04	60,1	0,36	0,95	cecomaf LBP
[°F]	-13	131	89,6	131										
[°C]	-35	40	20	40	51,2	175	44,1	1,14	3,89	0,98	45,0	0,31	0,62	EN12900 LBP
[°F]	-31	104	68	104										
[°C]	-6,66	54,4	35	46,1	192,5	657	165,6	2,18	7,46	1,88	88,1	0,46	2,29	ASHRAE MBP
[°F]	20	130	95	115										
[°C]	-10	55	32	55	151,5	517	130,4	1,82	6,21	1,57	83,3	0,44	1,99	cecomaf MBP
[°F]	14	131	89,6	131										
[°C]	-10	45	20	45	166,5	568	143,3	2,16	7,38	1,86	77,0	0,42	2,14	EN12900 MBP
[°F]	14	113	68	113										

Performance tables

220-240V/50Hz 1~, RSCR, static, VDE

	pe	Cooling capacity			COP	EER	P1	I	m		
	[°C]	[°F]	[W]	[Btu/h]	[kcal/h]	[W/W]	[Btu/Wh]	[kcal/Wh]	[W]	[A]	[kg/h]
[°C / °F]	-35	-31	49,5	169	42,6	1,09	3,73	0,94	45,3	0,31	0,59
cond. pressure	-25	-13	84,0	287	72,3	1,46	4,99	1,26	57,5	0,35	1,00
pc= 45/113	-15	5	138,1	472	118,9	1,96	6,70	1,69	70,3	0,39	1,65
return gas temp.	-10	14	173,2	592	149,1	2,25	7,68	1,94	77,0	0,42	2,07
RGT= 32/90	0	32	261,0	892	224,7	2,87	9,81	2,47	90,9	0,48	3,14
liquid temp	5	41	314,3	1073	270,5	3,20	10,94	2,76	98,1	0,51	3,80
Tliq= 45/113	10	50	374,1	1278	322,0	3,54	12,10	3,05	105,6	0,54	4,54
[°C / °F]	-35	-31	41,8	143	36,0	0,92	3,16	0,80	45,3	0,31	0,54
cond. pressure	-25	-13	72,6	248	62,5	1,21	4,12	1,04	60,1	0,36	0,95
pc= 55/131	-15	5	120,5	411	103,7	1,60	5,45	1,37	75,4	0,41	1,58
return gas temp	-10	14	151,5	517	130,4	1,82	6,21	1,57	83,3	0,44	1,99
RGT= 32/90	0	32	229,2	783	197,3	2,30	7,87	1,98	99,5	0,51	3,03
liquid temp	5	41	276,5	944	238,0	2,56	8,75	2,21	107,9	0,54	3,67
Tliq= 55/131	10	50	329,7	1126	283,8	2,83	9,67	2,44	116,4	0,58	4,39

Model

Designation **HXD55MA** **220-240V/50Hz** Conf. 2 Sales code: **CDO00080**

Configuration

Motorconfiguration RSIR
 Power supply (nominal) 220-240V/50Hz 1~
 Refrigerant R600a
 Application LBP+MBP
 Voltage range 187-254V
 Starting torque LST
 Approvals VDE

Electrical accessories / wiring diagram

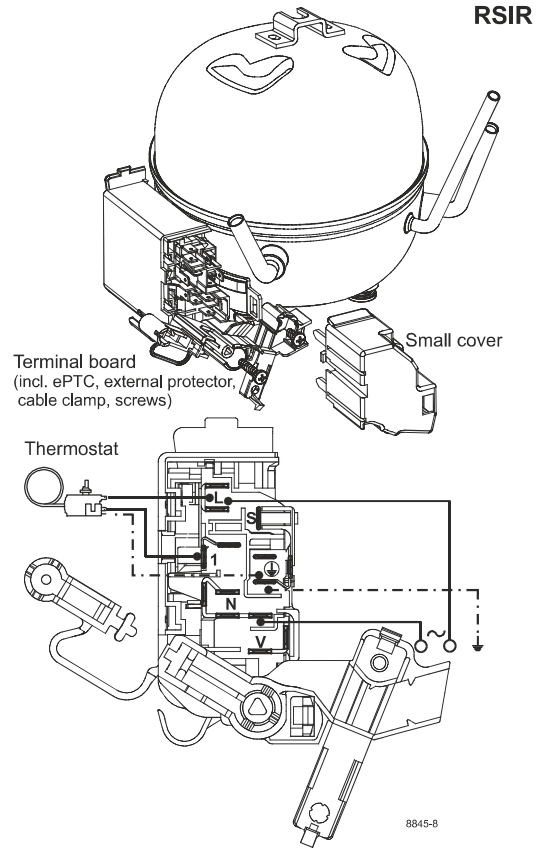

Ambient temperatures / system cooling

Ambient temperature min.: 10°C / 50°F
 Ambient temperature max.: 43°C / 110°F

System cooling			
T ambient	LBP	MBP	HBP
32°C / 90°F	static	static	n/a
38°C / 100°F	static	static	n/a
43°C / 110°F	static	static	n/a

Operation pressure range

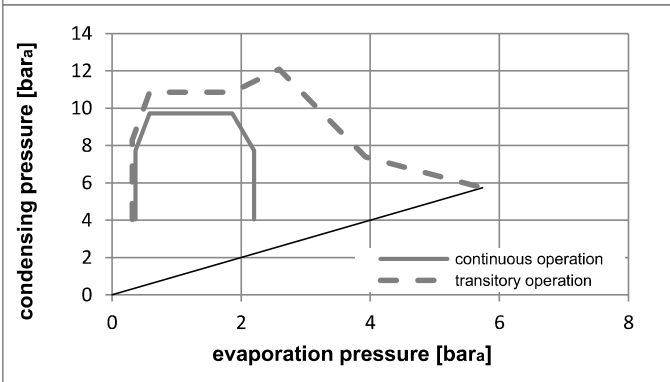
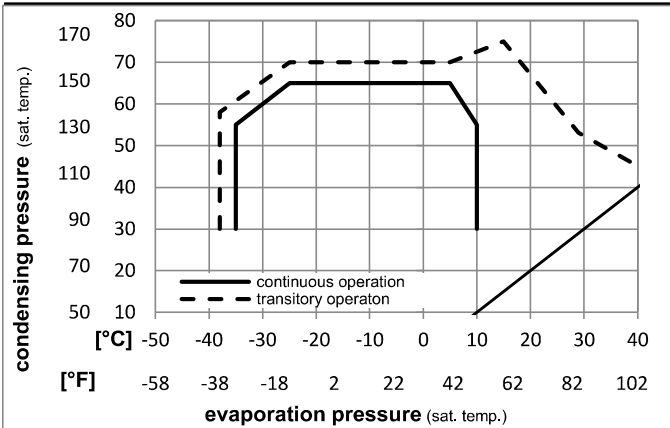

Components (will be pre-assembled)

- terminal board (ePTC,4.8mm) BX E4
- motor protector BDG AE 23 FLS 17 x E4
- cover terminal board 160943_

Model

Designation **HXD55MA 220-240V/50Hz** Conf. **2** Sales code: **CDO00080**

Optimization + standard conditions

220-240V/50Hz 1~, RSIR, static, VDE

	Evaporating pressure (saturation temperature)				Condensing pressure (saturation temperature)			Return gas temp.		Liquid temp.		Cooling capacity			COP	EER	Power consumption		Ref. mass flow	ASHRAE LBP
	pe	pc	RGT	Tliq	[W]	[Btu/h]	[kcal/h]	[W/W]	[Btu/Wh]	[kcal/Wh]	P1	I	[kg/h]							
[°C]	-23,3	54,4	32,2	32,2	96,7	330	83,2	1,47	5,02	1,26	65,8	0,36	1,04							
[°F]	-10	130	90	90																
[°C]	-25	55	32	55	72,6	248	62,5	1,15	3,92	0,99	63,2	0,36	0,95						cecomaf LBP	
[°F]	-13	131	89,6	131																
[°C]	-35	40	20	40	51,2	175	44,1	1,09	3,73	0,94	46,9	0,31	0,62						EN12900 LBP	
[°F]	-31	104	68	104																
[°C]	-6,66	54,4	35	46,1	192,5	657	165,6	2,04	6,98	1,76	94,2	0,46	2,29						ASHRAE MBP	
[°F]	20	130	95	115																
[°C]	-10	55	32	55	151,5	517	130,4	1,71	5,82	1,47	88,8	0,44	1,99						cecomaf MBP	
[°F]	14	131	89,6	131																
[°C]	-10	45	20	45	166,5	568	143,3	2,03	6,95	1,75	81,8	0,42	2,14						EN12900 MBP	
[°F]	14	113	68	113																

Performance tables

220-240V/50Hz 1~, RSIR, static, VDE

	pe	Cooling capacity			COP			EER			P1	I	m
	[°C]	[°F]	[W]	[Btu/h]	[kcal/h]	[W/W]	[Btu/Wh]	[kcal/Wh]	[W]	[A]	[kg/h]		
[°C / °F]	-35	-31	49,5	169	42,6	1,05	3,59	0,90	47,1	0,31	0,59		
cond. pressure	-25	-13	84,0	287	72,3	1,39	4,75	1,20	60,4	0,35	1,00		
pc= 45/113	-15	5	138,1	472	118,9	1,85	6,33	1,60	74,5	0,39	1,65		
return gas temp.	-10	14	173,2	592	149,1	2,12	7,23	1,82	81,8	0,42	2,07		
RGT= 32/90	0	32	261,0	892	224,7	2,68	9,17	2,31	97,3	0,48	3,14		
liquid temp	5	41	314,3	1073	270,5	2,98	10,19	2,57	105,3	0,51	3,80		
Tliq= 45/113	10	50	374,1	1278	322,0	3,29	11,24	2,83	113,7	0,54	4,54		
[°C / °F]	-35	-31	41,8	143	36,0	0,89	3,03	0,76	47,1	0,31	0,54		
cond. pressure	-25	-13	72,6	248	62,5	1,15	3,92	0,99	63,2	0,36	0,95		
pc= 55/131	-15	5	120,5	411	103,7	1,50	5,13	1,29	80,1	0,41	1,58		
return gas temp	-10	14	151,5	517	130,4	1,71	5,82	1,47	88,8	0,44	1,99		
RGT= 32/90	0	32	229,2	783	197,3	2,15	7,33	1,85	106,9	0,51	3,03		
liquid temp	5	41	276,5	944	238,0	2,38	8,13	2,05	116,2	0,54	3,67		
Tliq= 55/131	10	50	329,7	1126	283,8	2,62	8,95	2,26	125,8	0,58	4,39		