

Compresseur / Compressor
Code tension / Voltage code : F

RK5450Y

Conditionnement d'air
Air conditioning (A.C.)

220-240V / 50Hz - 1~

R134a

N° 313CH-F - ind d

Conditions <i>Conditions</i>	fréquence <i>frequency</i>	Prod frigorifique nominale / <i>nominal refrigerating capacity</i>			Puis. sonore <i>Sound level</i>
		Watts	Kcal/h	BTU/h	
Standard	50 Hz	1264	1087	4310	ISO 3745 / ISO 3743-1
Cecomaf	50 Hz	1128			62 dBA

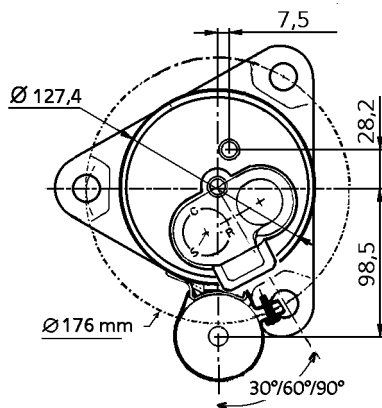
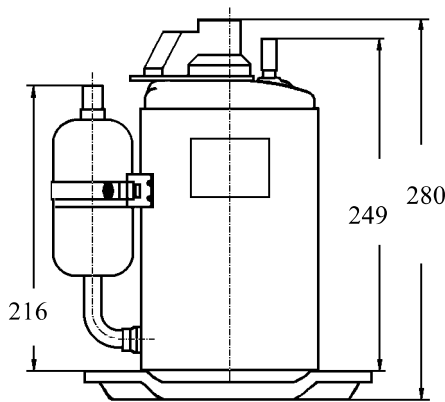

Cylindrée / Displacement : 11.4 cm³
Poids net / Net weight : 11.7 Kg
Charge en huile / Oil charge : 414 cm³
Type d'huile / Oil type : P.V.E. /
Détente / Expansion device : Capillaire
Capillary
Refroidissement / Cooling : Ventilé / *Forced*

Résistance à 20° C / Windings resistances at 20° C
 Phase princ. / *Main Winding :* 7.3 Ohms
 aux. / *Auxiliary Winding :* 11.4 Ohms

Intensité / Current
 nom. / *Rated current RLA :* 1.8 A
 max. / *Max current :* 2.8 A
 dém. / *Start current LRA :* 10 A

Ap. Electrique / Electrical equipment : CSR,PSC

Protecteur / Overload : T0057
 Temporisation / *Time check :* 7.5s - 14s / 8.5 A
 T° ouverture / *Opening temp.:* 105° C
 fermeture / *Closing temp. :* 60° C
 Option / *optional :* /

Relais potentiel / Potential relay : RVA2C**
 enclenchement / *Pick up :* 140/153V
 déclenchement / *Drop out :* 40/90V
 Option / *optional :* 3ARR3*3AL *

Condensateur dém. / Start capacitor: 21 µF / 330 V
Condensateur Perm. / Run capacitor : 15 µF / 400 V

Pour conduites Ø ext / *For tubing O.D.*

Aspiration <i>Suction</i>	Refolement <i>Discharge</i>	Charge <i>Process</i>
12.7 (1/2")	7.9 (5/16")	/

Les caractéristiques données dans cette fiche technique peuvent évoluer sans avis préalable, avec les améliorations que 'TECUMSEH EUROPE' entend toujours apporter à sa production.
 'TECUMSEH EUROPE', in a constant endeavour to improve its products reserves the right to change any information contained in this leaflet without prior warning.



RK5450Y	Tension F : 220 - 240V 1~ 50 Hz	R134a	N°313CH-F	Ind d
----------------	--	--------------	------------------	--------------

Les performances sont données dans les conditions Standard TE :	Surchauffe :	11°K
	Sous refroidissement:	8.3°K
The performance data are in Standard TE conditions :	Superheat :	11°K
	Subcooling :	8.3°K

50 Hz R134a											
4 T condensation	5 T évaporation	(°C)	-25	-20	-15	-10	-5	0	5	10	15
45	1 P frigorifique	(W)			643	760	920	1124	1370	1660	1992
	2 P absorbée	(W)			340	349	358	367	376	384	393
	3 I absorbée	(A)			1.52	1.57	1.62	1.67	1.71	1.76	1.81
55	1 P frigorifique	(W)					746	926	1144	1398	1688
	2 P absorbée	(W)					374	390	408	426	444
	3 I absorbée	(A)					1.66	1.73	1.81	1.89	1.97
60	1 P frigorifique	(W)						818	1019	1254	1521
	2 P absorbée	(W)						402	424	446	469
	3 I absorbée	(A)						1.76	1.85	1.95	2.05
65	1 P frigorifique	(W)							887	1101	1344
	2 P absorbée	(W)							439	466	494
	3 I absorbée	(A)							1.9	2.01	2.13
1 = refrigerating capacity 2 = watt input 3 = current 4 = condensing temperature 5 = evaporating temperature											

Nota : Les caractéristiques données dans cette fiche technique peuvent évoluer sans avis préalable, avec les améliorations que "TECUMSEH EUROPE" entend toujours apporter à sa production.

Note : "TECUMSEH EUROPE", in a constant endeavour to improve its products reserves the right to change any information contained in this leaflet without prior warning.