

24V C.C. - D.C.

VA03-BP70/LL-37A
VA03-BP70/LL-37S

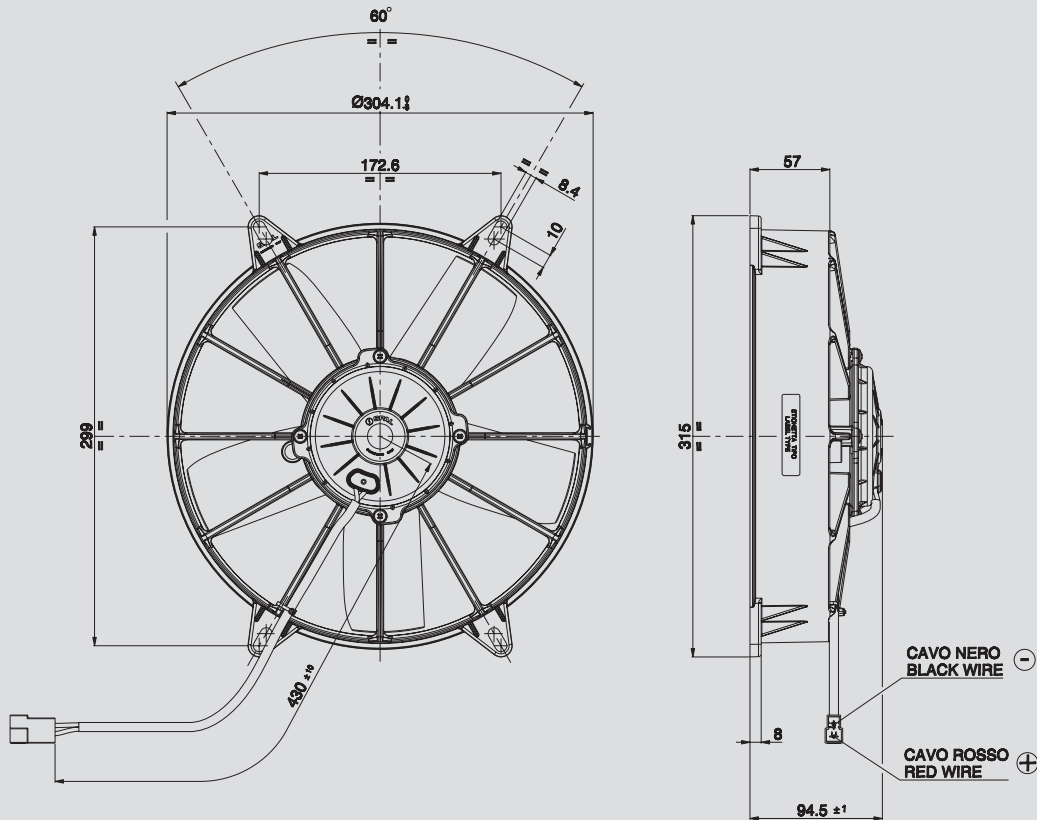

Suggested mounting torque: 3(+1/-0) Nm with screw M8
Weight 2.37 Kg. approx.

Coppia di serraggio consigliata: 3(+1/-0) Nm con vite M8
Peso 2,37 Kg. circa

Ø 280 mm
Ø 11"

suction / aspirante

blowing / soffiante

PRODUCT FEATURES
CARATTERISTICHE PRODOTTO

Static pressure Pressione statica mm H ₂ O	suction / aspirante			blowing / soffiante			Static pressure Pressione statica in H ₂ O
	Airflow Portata m ³ /h	Current input Corrente assorbita A	Airflow Portata CFM	Airflow Portata m ³ /h	Current input Corrente assorbita A	Airflow Portata CFM	
0	2480	7,0	1463	2310	6,2	1363	0
5	2260	7,5	1333	2080	6,5	1227	0,2
10	1970	7,7	1162	1840	6,9	1086	0,4
15	1510	7,7	891	1550	7,2	915	0,6
20	1000	7,9	590	1180	7,4	696	0,8
25	780	8,3	460	850	7,6	502	1
30	600	8,5	354	570	7,7	336	1,2
35	410	8,7	242	320	8,0	189	1,4
40	270	9,0	159	200	8,2	118	1,6
45	0	9,9	0	0	8,9	0	1,8

Waterproof motor, IP 68
Motore chiuso, IP 68



Long life / Lunga durata



VLL version* / Versione VLL*



Waterproof connector
Connettori a tenuta stagna



* for OEM applications only.
* per applicazioni OEM

✓ = Standard feature
Caratteristiche standard

✓ = Available upon request
Disponibile su richiesta

Test voltage 26 V. D.C. - Tensione di prova 26 V. c.c.