

12v C.C. - D.C.

VA09-AP12/C-54A
VA09-AP12/C-54S

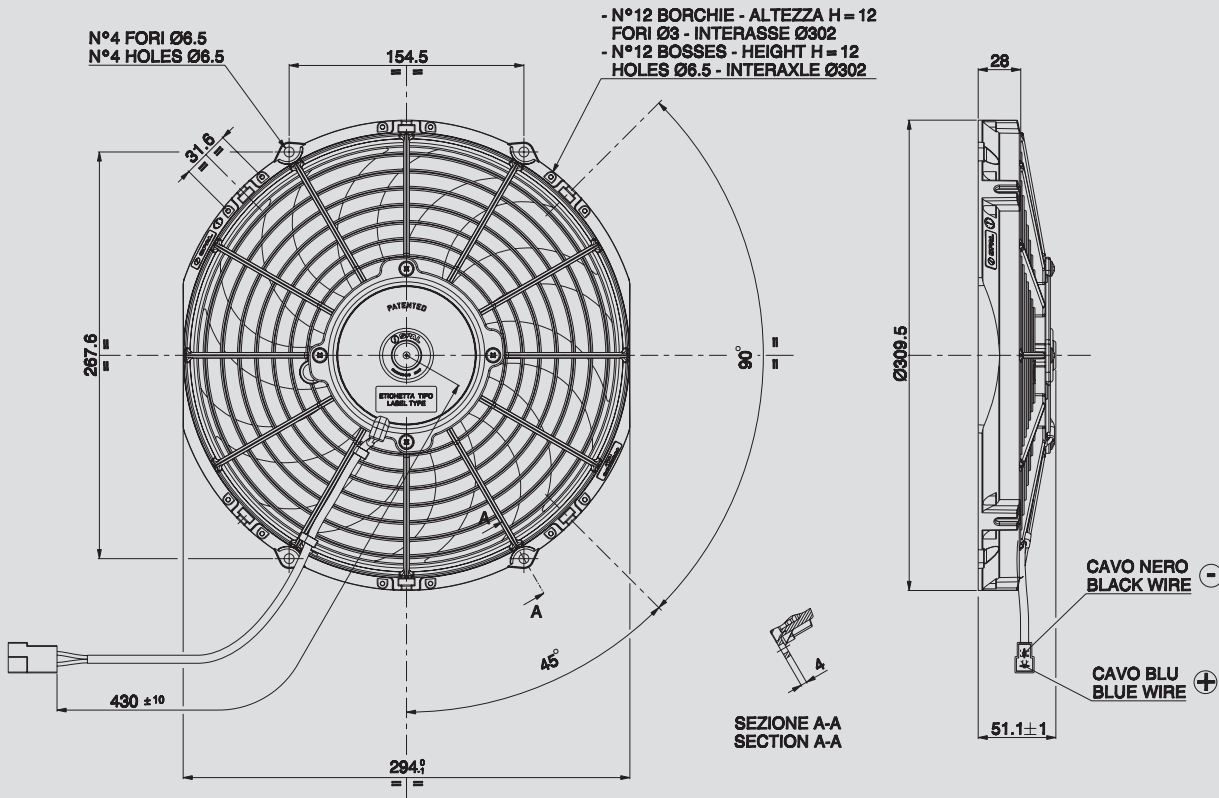

Suggested mounting torque: 3(+1/-0) Nm with screw M5
Weight 1,10 Kg. approx.

Coppia di serraggio consigliata: 3(+1/-0) Nm con vite M5
Peso 1,10 Kg. circa

Ø 280 mm
Ø 11"

suction / aspirante

blowing / soffiante

PRODUCT FEATURES
CARATTERISTICHE PRODOTTO

Static pressure Pressione statica mm H ₂ O	suction / aspirante			blowing / soffiante			Static pressure Pressione statica in H ₂ O
	Airflow Portata m ³ /h	Current input Corrente assorbita A	Airflow Portata CFM	Airflow Portata m ³ /h	Current input Corrente assorbita A	Airflow Portata CFM	
0	1430	7,8	844	1500	7,7	885	0
2,5	1310	8,0	773	1400	8,0	826	0,1
5	1080	8,0	637	1150	8,3	679	0,2
7,5	840	7,6	496	950	8,5	561	0,3
10	500	7,9	295	710	8,3	419	0,4
12,5	370	7,9	218	340	7,9	201	0,5
15	250	8,0	148	210	7,8	124	0,6
17,5	160	8,1	94	0	7,7	0	0,7
20	0	8,2	0				0,8

Waterproof motor, IP 68 Motore chiuso, IP 68	✓
Low noise / Bassa rumorosità	✓
Long life / Lunga durata	✓
LL and VLL version* Versione LL e VLL*	✓
Waterproof connector Connettori a tenuta stagna	✓
Accessories: all the fixing kits Accessori: tutti i kit di fissaggio	✓

* for OEM applications only.
* per applicazioni OEM

✓ = Standard feature
Caratteristiche standard
✓ = Available upon request
Disponibile su richiesta

Test voltage 13 V. d.c. - Tensione di prova 13 V. c.c.