

12v C.C. - D.C.

VA11-AP8/C-29A
VA11-AP8/C-29S

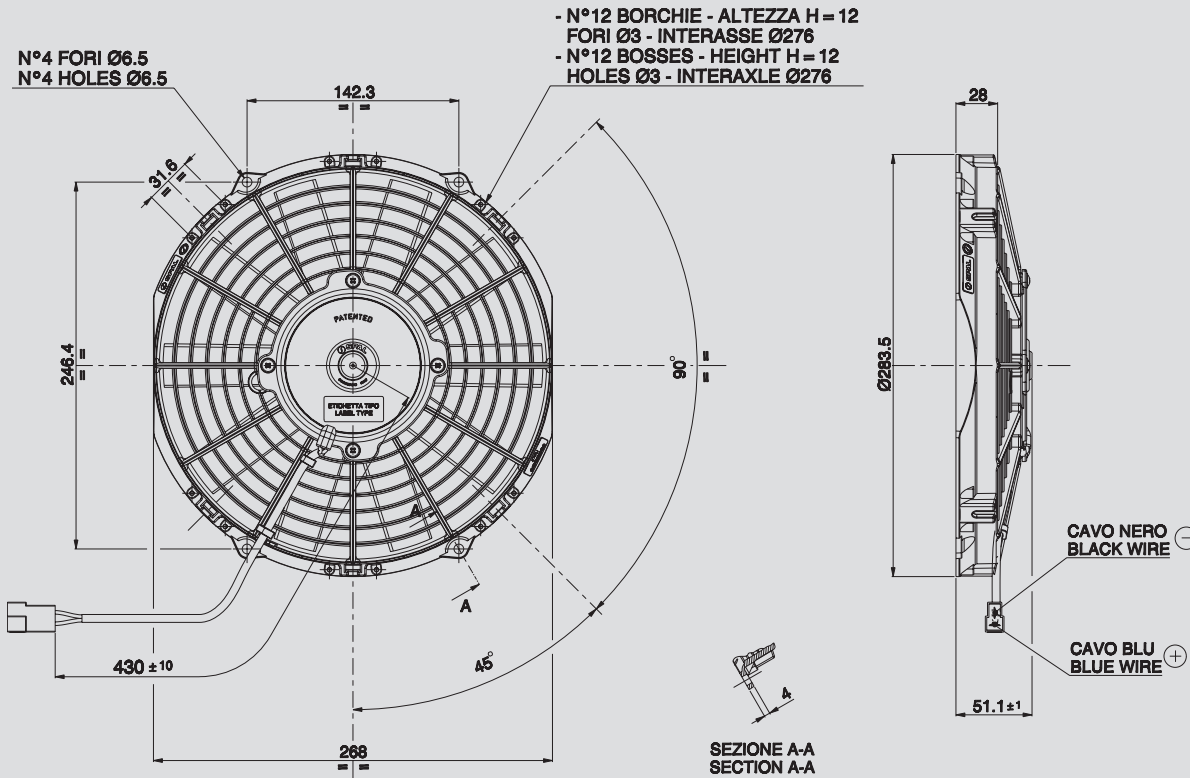

Suggested mounting torque: 3(+1/-0) Nm with screw M5
Weight 1,00 Kg. approx.

Coppia di serraggio consigliata: 3(+1/-0) Nm con vite M5
Peso 1,00 Kg. circa

Ø 255 mm
Ø 10"

suction / aspirante

blowing / soffiante

PRODUCT FEATURES
CARATTERISTICHE PRODOTTO

Static pressure Pressione statica mm H ₂ O	suction / aspirante			blowing / soffiante			Static pressure Pressione statica inH ₂ O
	Airflow Portata m ³ /h	Current input Corrente assorbita A	Airflow Portata CFM	Airflow Portata m ³ /h	Current input Corrente assorbita A	Airflow Portata CFM	
0	1090	5,8	643	1070	5,4	631	0
2,5	1000	5,9	590	950	5,5	561	0,1
5	850	6,0	502	840	5,5	496	0,2
7,5	780	6,2	460	690	5,6	407	0,3
10	580	6,1	342	460	6,0	271	0,4
12,5	380	6,2	224	290	5,7	171	0,5
15	270	6,2	159	0	5,7	0	0,6
17,5	0	6,2	0				0,7

Waterproof motor, IP 68 Motore chiuso, IP 68	✓
Long life / Lunga durata	✓
LL and VLL version* Versione LL e VLL*	✓
Waterproof connector Connettori a tenuta stagna	✓
Accessories: all the fixing kits Accessori: tutti i kit di fissaggio	✓

* for OEM applications only.
* per applicazioni OEM

✓ = Standard feature
Caratteristiche standard
✓ = Available upon request
Disponibile su richiesta

Test voltage 13 V. d.c. - Tensione di prova 13 V. c.c.