



Instructions for use

W0810

W0811

W0832

W0850

W3810

W3811

W7810

W7811

Temperature, relative humidity, atmospheric pressure and two-state signals transmitters for the SIGFOX network

© Copyright: COMET SYSTEM, s.r.o.

This manual is forbidden to copy and make changes of any nature without the express consent of COMET SYSTEM, s.r.o. All rights reserved.

COMET SYSTEM, s.r.o. constantly developing and improving its products. Therefore, it reserves the right to make technical changes to the device / product without prior notice.

Contact the manufacturer of this device:

COMET SYSTEM, s.r.o.
Bezrucova 2901
756 61 Roznov pod Radhostem
Czech Republic
www.cometsystem.com

Content

CONTENT	3
INTRODUCTION	4
SAFETY PRECAUTIONS AND PROHIBITED HANDLING.....	5
INSTALLATION	6
Mounting.....	6
Switching the device on	8
Displaying the device data	8
Device usage and settings	10
Alarm functions	11
MANUFACTURED MODELS	16
APPLICATION NOTES	21
OPERATING AND MAINTENANCE RECOMMENDATIONS.....	23
TECHNICAL PARAMETERS	25
Power supply	25
Measurement and transmission of data	25
Radio part	26
Electromagnetic compatibility	26
Operating and storage conditions	26
Mechanical properties	27
Transmitter Input Parameters.....	27
Dimensional drawings	33
Declaration of Conformity.....	36
APPENDICES	37

Introduction

The Sigfox network is used to transmit very short data messages and is optimized for low power consumption. It operates in the unlicensed radio band, which brings cheaper traffic, but also legislative restrictions – messages can not be sent faster than with a 10 minute interval.

Ideal applications for transmitters working in the Sigfox network are those where it is sufficient sending measured values with longer intervals (eg 1 h or longer). Conversely, inappropriate applications are those where fast system response (less than 10 minutes) is required.

The WX8xx series transmitters for the SIGFOX network are designed to measure:

- air temperature
- relative air humidity
- atmospheric air pressure
- binary signals

The transmitter performs a measurement every 1 minute. The measured values are displayed on the LCD and are sent over an adjustable time interval (10 min to 24 hour) via radio transmission in the Sigfox network to the cloud data store. Through a common web browser, the cloud allows you to view both actual and historical measured values. Transmitter setup is done either by computer (locally, by communication cable) or remotely via the cloud web interface.

For each measured variable, it is possible to set two alarm limits. The alarm is signalled by the symbols on the LCD display and sending an extraordinary radio message to the Sigfox network, where it is forwarded to the end user by e-mail or SMS message. Extraordinary messages can also be sent by the transmitter if the binary input state is changed (if equipped).

The device is powered by an internal Li battery whose lifetime is dependent on the transmission range and operating temperature and ranges from 4 months to 7 years. The battery status information is on the display and in each sent message.

The Wx8xx series transmitters are designed with increased resistance to external influences (especially water protection), see technical data.

Safety Precautions and Prohibited Handling



Read the following safety precautions carefully before using the appliance, and keep it in mind during use!

- The device includes a radio transmitter operating in the non-license frequency band with the power specified in the Technical Parameters. This band and performance are used in the countries of the European Union. If you are in another location, make sure you can use the device before turning it on for the first time.
- Do not use the device in places where the use of mobile phones, such as near sensitive medical devices, is restricted on the aircraft or in places where blasting is taking place.
- Observe the authorized storage and operating conditions listed in the Technical Specifications. Take care not to subject the unit to temperatures above 60 °C. Do not expose it to direct sunlight, including solar radiation.
- It is forbidden to use the transmitter in a hazardous environment, especially in areas with the risk of explosion of flammable gases, vapours and dust.
- It is forbidden to operate the unit without a cover. After replacing the battery or changing the instrument settings using the SP003 cable, check the seal integrity and screw the device with the original screws. Always follow the instructions in this manual carefully.
- Do not expose the device to aggressive environments, chemicals or mechanical shock. Use a soft cloth to clean. Do not use solvents or other aggressive agents.
- Do not attempt to service yourself. Any repairs may only be performed by trained service personnel. If the device has unusual behaviour, unscrew the device cap and remove the battery. Contact the distributor from whom you purchased the device.
- The device uses wireless communications and SIGFOX networks. For this reason, the connection cannot always be guaranteed and under all circumstances. Never rely exclusively on wireless devices for critical communication purposes (rescue systems, security systems). Keep in mind that redundancy is required for systems with high operational reliability. More detailed information can be found e.g. in IEC 61508.
- The device contains a special type of battery with other parameters than conventional AA batteries. Use the type recommended by the manufacturer in the Technical Parameters (Tadiran SL-760/S, 3.6 V, AA size).
- Replace the battery only with a person who knows the principles of safe handling of lithium primary batteries. Apply the used batteries to hazardous waste. In any case, do not throw them into a fire, expose them to high temperatures, low air pressure and do not mechanically damage them.
- Only use the manufacturer's recommended accessories.

Installation



Installation, commissioning and maintenance must only be carried out by a qualified person in accordance with applicable regulations and standards.

Mounting

For the optimum operation of the Wx8xx Series, it is necessary to ensure their vertical position. Models without external probes or sensors may loosely stand on their bottom base as required, and other models are recommended to fix in the vertical position. Device boxes are fitted with a pair of 4.3 mm diameter holes for fixing, for example, with screws or straps.

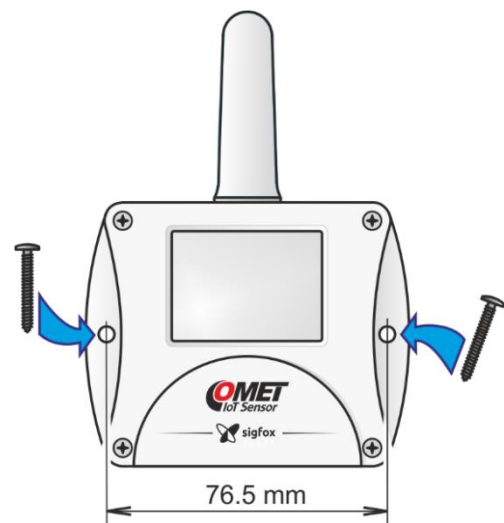

Basic placement rules:

- Always install the transmitters vertically, with the antenna cover up, at least 10 cm away from all conductive objects
- Do not install the devices in underground areas (the radio signal is generally unavailable here). In these cases, it is preferable to use the model with an external probe on the cable and place the device itself, for example, one floor above.
- The devices and all cables (probes, binary inputs) should be placed away from electromagnetic interference sources.
- Temperature and relative humidity transmitters, or their probes, should be placed so that the measured values are not affected by accidental heat sources (sunshine ...) and unwanted airflow
- probe of temperature and relative humidity sensors (W3811 or W7811) mount the cap vertically with the cap downwards to prevent accumulation of any water condensate in the sensor compartment (otherwise, it may increase the response time to change humidity or even damage the sensors)

Optimal positioning of the transmitter in terms of radio range:

All materials absorb radio waves if they must pass through them. The most significant in terms of radio wave propagation are metal objects, concrete, reinforced concrete and walls. If you install the device at a greater distance from the base station or in locations where the radio signal difficult to penetrates, observe the following recommendations:

- place the device as high as possible with the antenna better in open space than near the wall
- in rooms place the device at least 150 cm above the floor and if possible not directly on the wall. For safety reasons, you do not exceed the installation height of 2 m above the floor (the fall of the insufficiently attached device can be dangerous)
- place the device at a sufficient distance (at least 20 cm) away from all obstacles that could cause attenuation of the radio waves and at least 20 cm from the neighbouring device in the case that you use multiple devices
- lead the cables of the external measuring probes or binary inputs first down to the distance of at least 40 cm from the instrument. If the cable is too long, install it by the figure.
- do not use probes with a cable shorter than 1 m

Examples of optimal and less suitable positioning of the device:

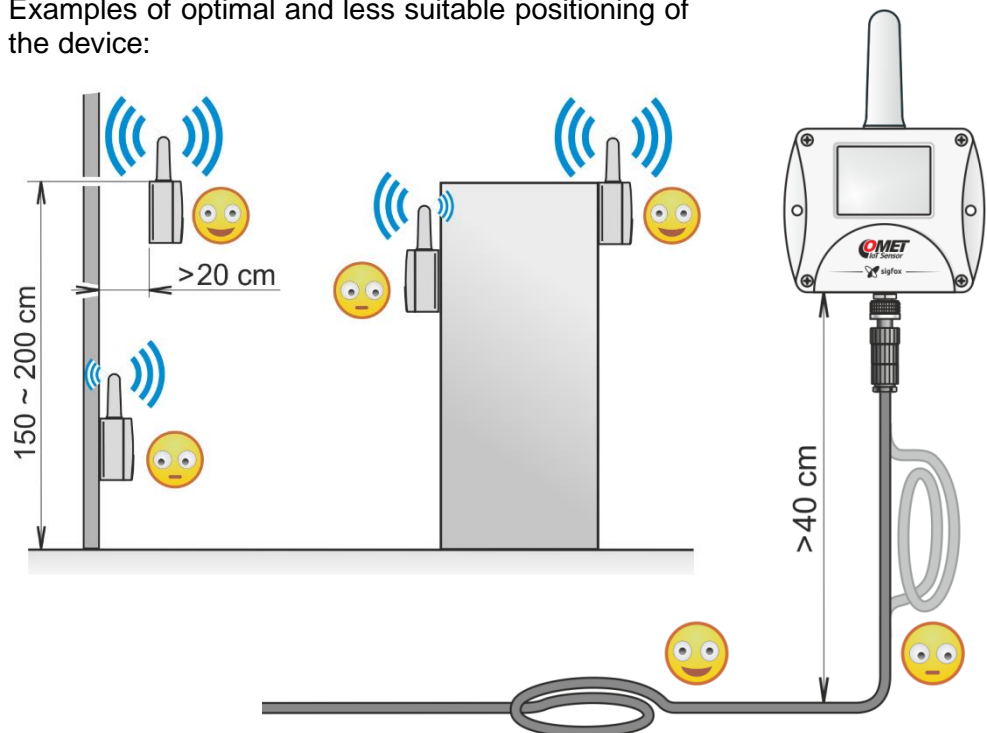

Switching the device on

The device is supplied with installed battery, but in off state. To turn on:

- Unscrew the four screws at the corners of the box and remove the cover
- Press the CONFIGURATION button using e.g. a pencil (see figure) and release it as soon as the LCD lights up (through the 1 s)
- If necessary, perform the device setup (see chapter *Device usage and settings*).
- Carefully tighten the cover of the instrument, making sure that the gasket in the housing groove is correctly positioned

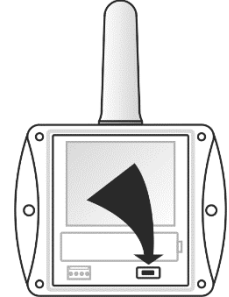

Displaying the device data

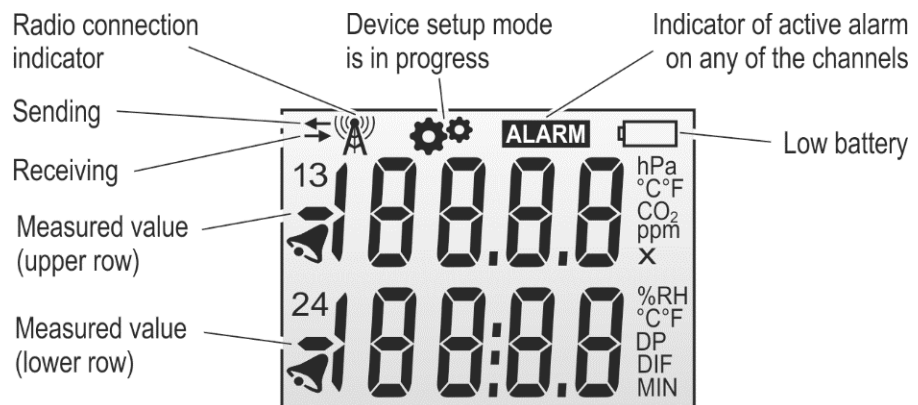

Radio Connection Indicator – Indicates the result of checking the bi-directional radio connection with the cloud, which takes place once a day. This connection allows the transmitter to be set remotely. If the radio connection check is successful, the indicator will remain lit until the next scan. When the transmitter is switched on, the indicator lights up after 24 h (a good radio signal is required). The Radio connection indicator may light up sooner if the user deliberately selects the transmitter setting mode by pressing the CONFIGURATION button (under the device cover) and it is correctly performed.

If the remote setting in the device is disabled, the bi-directional connection check to the cloud is not performed and the radio connection indicator remains off.

Low Battery Symbol – Illuminates if the battery is already weak and flashes when the battery is in critical condition (see the Battery replacement procedure chapter for details)

Information on the display – they are displayed cyclically in three steps (the images below contain only examples of the display, the content of the display always depends on the specific device model):

1. step (lasts 4 sec) the display shows data on measured quantities on channels No.1 and No.2

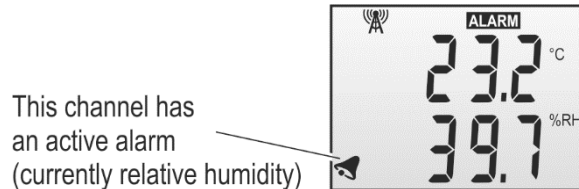

2. step (lasts 4 sec) the display shows data on measured quantities on channels No.3 and No.4

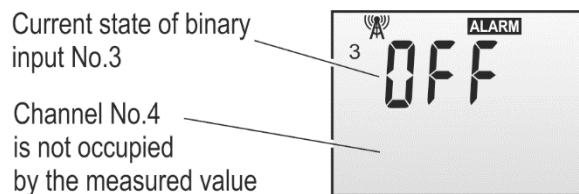

3. step (lasts 2 sec.) The display shows the service information about the time of sending regular messages



8x - shows how many times the regular message will be sent before the new transmitter setup (if this requirement is currently set in the cloud). The information is reduced with each regular report sent. Reading the new settings from the cloud occurs when the display shows "1x 0 min". If the remote setting is in the device disabled, this line is not displayed.

30 min - The time in minutes until a regular message with measured values is sent (the information decreases every minute from the currently set sending interval to 0)

Device usage and settings

Factory setting

- Message sending interval of 10 minutes
- Alarms deactivated
- Remote setting enabled
- For instruments with pressure measurement set altitude 0 m
- Two-state inputs are set to connect a voltage-free contact

Working with the cloud

Viewing measured values

Cloud is an internet storage of data. You need a PC with internet connection and a web browser to work with. Navigate to the cloud address you use and sign in to your account - if you use COMET Cloud by a transmitter manufacturer, enter www.cometsystem.cloud and follow the instructions in the *COMET Cloud registration* document that you received with your device.

Each transmitter is identified by its unique address (device ID) in the Sigfox network. The transmitter has an ID printed on the nameplate along with its serial number. In the list of your device in the cloud, select the device with the desired ID and start viewing the measured values.

Checking the signal quality during device installation.

The device in factory default setting will send the measured values every 10 minutes. Check in the cloud for messages to be received. Place the device temporarily to the location where it will perform the measurements and check the quality of the radio signal – in COMET Cloud click on the correct device in the *Devices* list and then select *Installation*. If you have a problem with the signal, see the *Problems with receiving radio messages* chapter.

Change of device settings remotely

The transmitter can be set remotely from the cloud if the cloud you use supports this feature. Run the remote setting feature - in COMET Cloud click on the correct device in the *Devices* list and then select *Configure*. Set the desired sending interval (taking into account the fact that for short sending intervals the battery life decreases), the limits, delays and hysteresis of the alarms for the individual quantities (if used), or correction of the altitude atmospheric pressure (only models with air pressure measurement). Save the new setting. The device will accept this new setting within 24 hours at the latest.

If you are running a new transmitter and want to speed up the setting, press the CONFIGURATION button on the uncovered device (the device must be switched on beforehand) - the setting symbol  (gears) lights up and

the device will start transmitting the new setting from the cloud within 10 minutes. The transmission itself will take up to 40 minutes depending on the range of the new settings. The function can only be used once every 24 hours.

Working with the COMET Vision SW

Change of device settings by connecting to a PC

The transmitter can be set directly from the PC using the SW COMET Vision and Communication Cable SP003 (Optional accessory). Software COMET Vision is downloadable on the web www.cometsystem.com, as well as a manual for its installation and use.

Unscrew the device cover and connect it to the SP003 cable with the USB port on the computer. Start the Comet Vision program and make a new device setting. After you have saved the new settings, unplug the cable and screw the device cover carefully. Pay attention to the correct seal position.

Warning – do not leave the communication cable SP003 connected to the transmitter if the cable is not connected to the PC USB port at the same time or if the PC is switched off! The battery consumption in these cases increases and the battery is drained unnecessarily

Alarm functions

The transmitter sends the measured values in regular messages, according to the set sending interval. In addition, the transmitter can also send extraordinary alarm messages when a new alarm is generated on a tracked channel or the alarm in progress is extinguished. This feature allows you to extend the battery life by setting a longer sending interval for regular messages, and the user is informed about changes in the alarm status by extraordinary messages according to the current situation.

Overview of transmitter properties for correct alarm function settings

- Two alarms can be set for each measured quantity
- Each alarm has an adjustable limit, direction of exceeding the limit, delay (0-1-5-30 min) and hysteresis
- The longer the period for sending regular messages, the greater the capacity of the battery is saved
- After a new alarm is triggered (or an alarm is ended), an extraordinary alarm message is sent within 10 minutes at the latest. Temporary interruption of the current alarm (max. 10 min) is not indicated. See the examples in pics below.

-
- The content of both regular and extraordinary alarm messages is identical, both contain the measured values of all channels and current alarm states on all channels
 - No even a short-term alarm (i.e. with a duration of 1 to 10 min) will not be lost – the information will be sent no later than 10 min even if the alarm is currently inactive. Device in alarm message sends the maximum value measured during the alarm duration (or the minimum value, depending on the current alarm threshold setting). See the examples in pics bellow.
 - Due to the regulation of the unlicensed radio band, the device can not send messages faster than every 10 minutes. If the device has fastest sending interval (ie 10 minutes), no extraordinary alarm messages can be sent.

In addition, for devices with binary inputs:

- for both binary states can be assigned one of the 32 predefined descriptions that appear on the device screen (e.g. On, Off, Open, Close, Hi, Lo, Run, Full, Done etc.)
- binary input alarms have an adjustable delay only (0-1-5-30 min)
- for device display and alarm evaluation, binary inputs are sampled every 1 sec
- changes on binary input states are always evaluated at a fixed interval of 10 minutes (independently of the set sending interval), and any changes detected are immediately sent by extraordinary messages. Events less than 10 minutes may not be detected. You can deactivate this feature by selecting "Suppression of input changes sending" in the device configuration. This is useful when users are only interested in alarm states and posting of (frequent) changes to binary inputs would unnecessarily reduce the battery life.
- the alarm on the binary input is checked every 1 sec and if activated (or ended), extraordinary alarm message is sent within 10 min. Temporary interruption of the current alarm (max. 10 min) is not indicated. See the examples in pics bellow.
- Neither a short-term alarm (with a duration 1 s to 10 min) will be not lost – the information will be sent no later than 10 minutes, even if the alarm is already currently ended. See the examples in pics bellow.
- If the alarms function is turned OFF on the binary inputs and the "Suppression of input changes sending" function is turned ON, no extraordinary messages are sent. The user is informed about the binary inputs state in regular messages only – according to the currently set sending interval.

Examples of sent alarm messages triggered by changes in the measured value (eg temperature)

Device configuration:

- sending interval: 30 min
- alarm for channel temperature: ON
- alarm will be activated if: value is greater than limit
- limit of alarm: any value
- delay of alarm: none
- hysteresis: 0 °C

After a new alarm is triggered, an extraordinary alarm message is sent within 10 minutes at the latest. Temporary interruption of the current alarm (max. 10 min) is not indicated. After ended of alarm, an extraordinary alarm message is sent within 10 minutes at the latest.

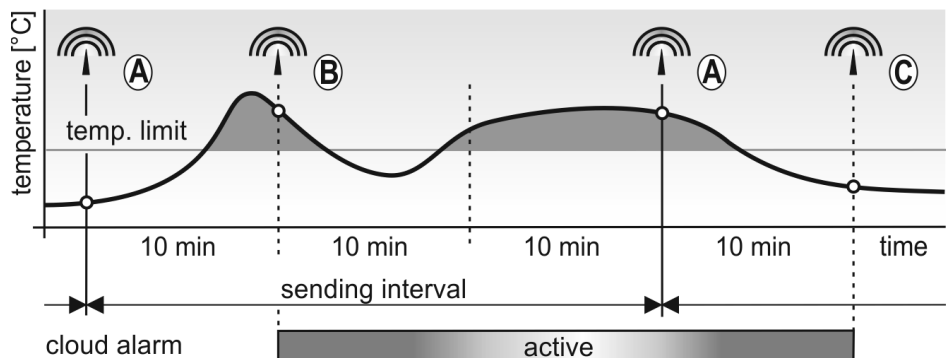

- (A) regular message sent in sending interval
- (B) extraordinary message - start of alarm
- (C) extraordinary message - end alarm

No even a short-term alarm (i.e. with a duration of 1 to 10 min) will not be lost – the information will be sent no later than 10 min even if the alarm is currently inactive. Device in alarm message sends the maximum value measured during the alarm duration.

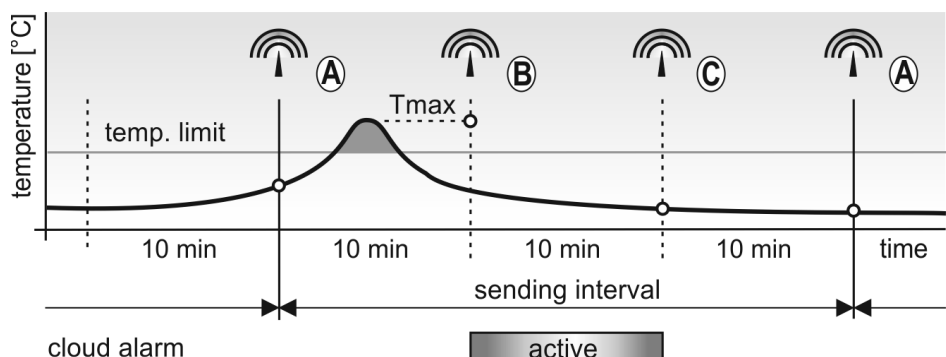

- (A) regular message sent in sending interval
- (B) extraordinary message – start of alarm
- (C) extraordinary message – end alarm

Examples of sent messages triggered by changes on the binary input

Device configuration:

- both alarms for this input: OFF
- suppression of input changes sending: OFF

Changes on binary input states are always evaluated at a fixed interval of 10 minutes, and any changes detected are immediately sent by extraordinary messages.

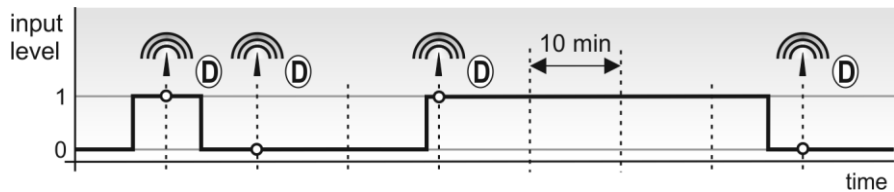

(D) extraordinary message – change in state of input

Device configuration:

- alarm for this input: ON
- alarm will be activated if input state: 1
- delay of alarm: 30 min
- suppression of input changes sending: OFF

Changes on binary input states are always evaluated at a fixed interval of 10 minutes, and any changes detected are immediately sent by extraordinary messages. The alarm on the binary input is checked every 1 sec and if activated (or ended), extraordinary alarm message is sent within 10 min.

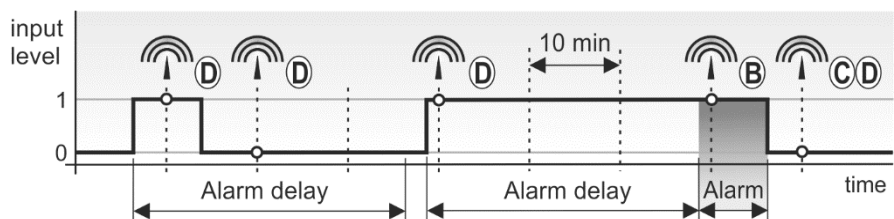

(B) extraordinary message – start of alarm

(C) extraordinary message – end alarm

(D) extraordinary message – change in state of input

Device configuration:

- alarm for this input: ON
- alarm will be activated if input state: 1
- delay of alarm: none
- suppression of input changes sending: OFF

Changes on binary input states are always evaluated at a fixed interval of 10 minutes, and any changes detected are immediately sent by extraordinary messages. The alarm on the binary input is checked every 1 sec and if activated (or ended), extraordinary alarm

message is sent within 10 min. Neither a short-term alarm (with a duration 1 s to 10 min) will be not lost – the information will be sent no later than 10 minutes, even if the alarm is already currently ended. Temporary interruption of the current alarm (max. 10 min) is not indicated.

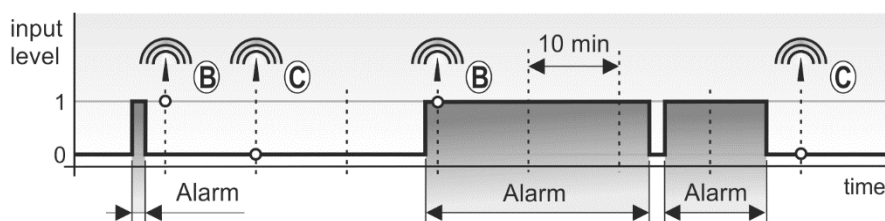

(B) extraordinary message – start of alarm
(C) extraordinary message – end alarm

Device configuration:

- alarm for this input: ON
- alarm will be activated if input state: 1
- delay of alarm: 30 min
- suppression of input changes sending: ON

The alarm on the binary input is checked every 1 sec and if activated (or ended), extraordinary alarm message is sent within 10 min.

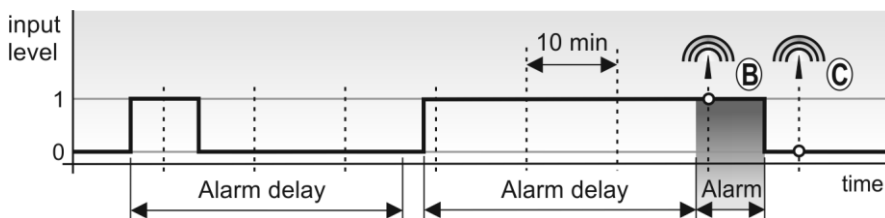

(B) extraordinary message – start of alarm
(C) extraordinary message – end alarm

Device configuration:

- both alarms for this input: OFF
- suppression of input changes sending: ON

Information about the binary inputs state are sent in regular messages only – according to the currently set sending interval.

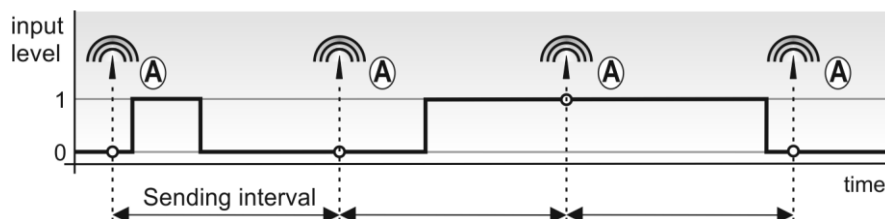

(A) regular message sent in sending interval

Manufactured models

COMET's Wx8xx transmitters differ in the type of measured quantities (temperature, relative humidity, atmospheric pressure, two-state signals) and the location of the sensors (compact design with internal sensors or external probes on the cable).

The enclosure covers electronic circuits, internal sensors, and a battery. Depending on the type, the devices are fitted with connectors. The antenna is protected by a cap.

W0810

Compact temperature transmitter

The transmitter only measures the temperature from the built-in internal sensor, no probes and sensors are connected to it. It features a simple compact design and a relatively long response to step change in temperature. It is placed directly into the measured area.

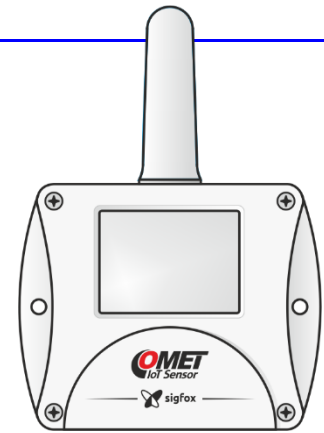

W0811

Temperature transmitter for external Pt1000 probe

The transmitter measures the temperature from external probes of the Pt1000/E line (the probe is not part of the instrument). Response to the jump temperature change is usually much faster than the models from the internal sensor. The transmitter is often used to monitor locations where only a measuring probe is installed and the device itself is in a suitable location from a radio range point of view. The maximum recommended probe length is 15 m.



W0850

Temperature transmitter with binary inputs

The transmitter measures one temperature from the built-in internal sensor. In addition, it has two binary inputs (input No. 2 and No. 3) to monitor voltage changes or to monitor the non-voltage contact state. Binary inputs **are designed to track relatively slow actions** because the information cannot be sent faster than every 10 minutes. The state of binary inputs for displaying is scanned once per second, faster changes may not be noticed (for details, see the chapter *Alarm functions*). Changes to binary inputs are sent to the cloud by extraordinary messages with a delay of up to 10 minutes. The input signals are connected using a 1 m long cable. The instrument is positioned directly in the measured area and is characterized by a relatively long response to a step change in temperature. The length of the shielded binary input cable should not exceed 15 m.

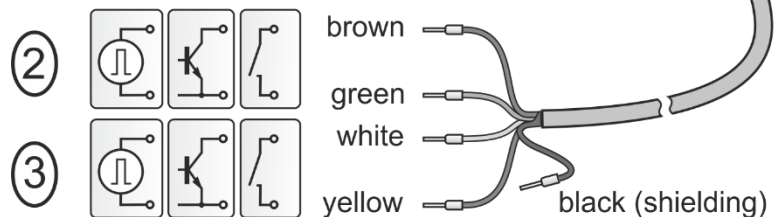
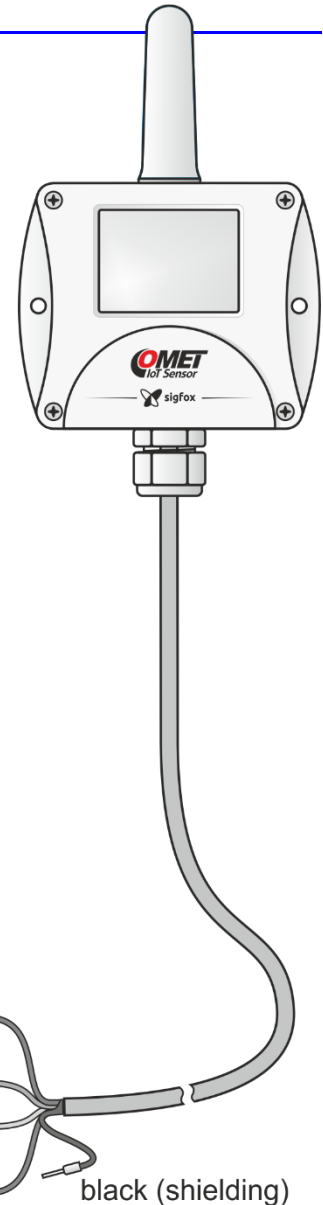

W0832

Thermometer with s built-in internal sensor and two inputs for external Pt1000 probe

The device measures the temperature from two external probes of the Pt1000/E line (input No. 1 and No. 2) and from the built-in internal sensor (input No. 3). The probe is not part of the instrument. It features for internal sensor is a relatively long response to step change in temperature. Response to the temperature change for external probes is usually much faster. The transmitter is often used to monitor locations where only a measuring probe is installed and the device itself is in a suitable location from a radio range point of view. The maximum recommended probe length is 15 m.



W3810

Compact temperature and relative humidity transmitter

The transmitter measures the temperature, relative humidity and dew point temperature by means of internal sensors located under the cap with a stainless-steel air filter. The device is characterized by a simple compact design, but a relatively longer response to a step change in temperature and humidity than those with an external probe. The instrument is placed directly into the measured area.



W3811

Temperature and relative humidity transmitter for external Digi/E probes

The transmitter measures the temperature, relative humidity and dew point temperature from the COMET Digi/E external probe (the probe is not part of the instrument). Response to jump-change of temperature and relative humidity is significantly faster than models with internal sensor. The device is often used to monitor locations where only the probe is placed and the instrument itself is not in the measured area. Therefore, during installation, it may be easier to find the right place for radio link optimization than for compact models. The maximum length of the probe must not exceed 15 m. Digi/E series probes provide calibrated measured values and are therefore interchangeable without having to interfere with the instrument settings.



W7810

Compact temperature sensor, relative humidity and atmospheric pressure

The transmitter measures temperature, relative humidity, dew point and atmospheric pressure with internal sensors. The temperature and relative humidity sensors are located under the cap with a stainless-steel air filter, the atmospheric pressure sensor is inside the device. The transmitter is characterized by a simple compact design, but a relatively longer response to a step change in temperature and humidity than those with an external probe. The device is placed directly into the measured area.



W7811

Compact temperature, relative humidity and atmospheric pressure transmitter for external Digi/E probes

The transmitter measures the temperature, relative humidity and dew point temperature from the COMET Digi/E probe (not included). It also measures atmospheric pressure with an internal sensor. The response to step change in temperature and relative humidity is considerably faster than for models with an internal sensor. The transmitter is often used to monitor locations where only a measuring probe is installed and the device itself is in a suitable location from a radio range point of view. The maximum length of the probe must not exceed 15 m. Digi/E series probes provide calibrated measured values and are therefore interchangeable without having to interfere with the instrument settings.



Application notes

Operation of transmitter in various applications

Prior to commissioning, it is first necessary to assess whether its use is appropriate for the purpose, to determine its optimum setting and, if it is part of a larger measuring system, to prepare a metrological and functional control.

Inappropriate and risky applications: The transmitter is not intended for applications where the failure of its operation could directly endanger the lives and health of persons and animals or the function of other devices that support life functions. For applications where failure or malfunction could result in serious property damage, it is recommended that the system be supplemented by a suitable independent signalling device that evaluates this status and, in the event of a malfunction, prevents the damage (see chapter *Safety precautions and forbidden handling*).

Device location: Follow the guidelines and procedures in this manual. If possible, select the location for the device where it is minimally affected by external environmental influences. If you perform measurements in fridges, metal boxes, chambers, etc., place the device outside the exposed area and insert external probe(-s) only.

Location of temperature sensors: Place them in places where there is sufficient airflow and where you anticipate the most critical location (according to application requirements). The probe must be sufficiently inserted or otherwise sufficiently connected to the measured area to prevent any influence of the measured values by the undesirable heat supply on the wires. If you monitor the temperature in the air-conditioned store, do not place the sensor in the air conditioner direct flow. E.g. in large chamber refrigerators, the distribution of the temperature field can be very inhomogeneous, deviations may reach up to 10 ° C. You will also find the same deviations in the deep-freeze box (e.g. for blood freezing, etc.).

The location of the humidity sensors depends again on the application requirements. It is very problematic to measure moisture in refrigerators without moisture stabilization. Switching on / off cooling may cause significant changes in humidity to a range of tens of percent, even if the humidity mean value is correct. Humidity condensation on the walls of the chambers is common.

Measurement of calculated humidity variables

The instrument from the calculated humidity variables only provides the dew point temperature. Further calculated humidity quantities can be obtained at the level of further data processing in SW.

Measurement of atmospheric pressure _____

Models with atmospheric pressure measurement allow display on sea level pressure readings. In order for the conversion to be correct, you must, during device configure, enter the altitude at which the device will be located. Altitude can be entered either directly, in the form of altitude data, or indirectly, as an offset of absolute pressure. Offset of pressure is the subtraction of pressure required (ie converted to sea level) minus absolute pressure.

When converting pressure to sea level, the device takes into account the temperature of the air column at the point of air pressure measurement. Therefore, it is necessary to place the device with the altitude correction in the outdoor. If this device is placed in a heated room, the error in the recalculated pressure measurement will increase with the temperature difference between the device and the outdoor air increases.

Problems with measurement accuracy _____

Incorrect measured values of temperature and relative humidity are most often caused by inadequate probe position or measurement methodology. Some notes on this issue are listed in the chapter *Operation of transmitter in various applications*.

Another group of problems are random peaks in the measured values. Their most common cause is the source of electromagnetic interference near the instrument or cables. In addition, it is also necessary to focus on whether cable insulation is damaged in any place and that there are no accidental connections of conductors with other metal parts.

Problems with receiving radio messages _____

The causes of the problems can be many. If the receive of radio messages does not work at all, you can try the following steps:

- Check whether the display is on and that the battery is weak
- Verify that the set transmission interval matches your expectations (on the bottom line of the display, with of the 10 seconds interval always for 2 seconds shows the number of minutes left until the message is sent)
- Verify the coverage of the SIGFOX network for the transmitter (<https://www.sigfox.com/en/coverage> or more detailed <http://coverage.simplecell.eu/>)

Transmitting from the interior of some buildings can be difficult, from basements, as a rule, impossible. For testing purposes, therefore, position the device as high as possible above the floor, put it on the window, or even on the outside windowsill (secure the device against falling). If possible, test the location of the transmitter in other parts of the building with respect to the world's sides.

Operating and maintenance recommendations

Recommendations for metrological control _____

Metrological verification is performed according to the requirements of your own application in user-defined terms. In some cases, the calibration must be performed by an independent state-accredited laboratory.

Recommendations for regular checks _____

The manufacturer recommends that the system in which the device is incorporated be checked at regular intervals. The range and scope of the tour depends on the application and the user's internal regulations. It is recommended to perform these checks:

- Metrological verification
- Regular checks at intervals as specified by the user
- Evaluation of all the problems that have occurred since the last inspection
- Visual inspection of the device, check the condition of connectors and cables, and cover integrity

How to replace the battery _____



The battery may only be replaced by a person who knows the principles of safe handling of lithium primary batteries. Do not throw them into a fire, do not expose them to high temperatures, and do not mechanically damage them. Dispose the used batteries to hazardous waste.

If the low battery symbol  starts to appear in the COMET cloud received messages during operation, it is advisable to replace the transmitter battery in the next 2-3 weeks. The empty battery symbol also appears on the device display. A low battery indication may also occur if the device is operated at extremely low temperatures even when the battery is still usable (usually outdoors when in out-of-night messages). During the day (after temperature rise), the indication disappears. In this case, it is not necessary to change the battery.

A critically weak battery that can fail at any time is indicated by a blank battery symbol  in the COMET cloud and flashing the empty battery symbol on the device display. Replace the battery as soon as possible.

Note: When operating the transmitter at very low temperatures, the flashing of the blank battery symbol may not be on the sensor display visible.

To replace the battery, unscrew the device cover, remove the old battery by pulling on the glued handle, and insert the new battery with the **correct polarity**. Refer to the battery symbol + (plus pole) printed on the electronics board at the battery location:

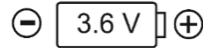

If you order a new battery from the device manufacturer (COMET SYSTEM, s.r.o., order code A4203), you will also receive it with the glued handle. Check the seal integrity in the housing and reinstall the cover.

Service Recommendations

Technical support and service are provided by the distributor of this device. Contact is provided in the warranty sheet supplied with the device.

WARNING - Improper handling or use of the device results in a loss of warranty!

End of operation

Disconnect the measuring probes from the device. Return the device to the manufacturer or dispose it as an electronic waste.

Technical parameters

Power supply

The device is powered by an internal lithium battery, accessible after unscrewing the cover (see the section How to replace the battery).

Power batteries

Battery type:

Lithium battery 3.6 V, AA size, 2200 mAh

Recommended type: Tadiran SL-760/S, 3.6 V, 2200mAh

Battery life:

<u>Message sending interval</u>	<u>Battery life</u>
10 minutes	4 months
20 minutes	7 months
30 minutes	11 months
1 hour	1.5 year
3 hours	3.5 years
6 hours	5 years
12 hours	6 years
24 hours	7 years

- *the values given is valid for the operation of the device in the temperature range -5 to + 35 ° C. Frequent operation outside this range reduces battery life by up to 25 %.*
- *these values apply in the case where extraordinary alarm messages are not used or only exceptionally*
- *if the remote setting in the transmitter is disabled, the battery life increases slightly, reaching up to 8 years for 24 hours*

Measurement and transmission of data

Measuring interval:

1 minute

Message sending interval:

Adjustable for 10 minutes, 20 minutes, 30 minutes, 1 hour, 3 hours, 6 hours, 12 hours, 24 hours

Radio part

Working frequency:

Transmission is in the band 868.130 MHz
Reception is in the band 869.525 MHz

Maximum transmission power:

25 mW (14 dBm)

Antenna:

Internal, gain 2 dBi

Minimum receiver sensitivity:

-127 dBm @600bps, GFSK

Sigfox radiation class:

0U

Radio configuration zone:

RC1

Typical range from base station:

50 km in open field, 3 km in urban area

For correct operation, the device position must be maintained,
the antenna vertically upward!

Electromagnetic compatibility

ETSI EN 301 489-1 V1.9.2
ETSI EN 301 489-3 V1.6.1.
EN 61326-1 ed.2:2013

Operating and storage conditions

Operating temperature:

(-30 to +60) °C
Display visibility is within range (-20 to +60) °C

Operating humidity:

(0 to 100) %RH without permanent condensation

Operating environment:

Chemically non-aggressive

Working position:

vertically, the antenna top

Storage temperature:

(-20 to +45) °C

Storage humidity:

(5 to 90) %RH

Mechanical properties

Dimensions (H x W x D):

126 x 89 x 40 mm without the cables and connectors attached (see dimensional drawings in detail below)

Weight including battery:

W0810 150 g

W0811, W3810/3811, W7810/7811 155 g

W0832 160 g

W0850 200 g

Case material:

ASA

Protection:

W0810, W0811, W0832, W0850, W3811: IP65

W3810, W7810: IP65, sensors under the cap IP40

W7811: IP54

Transmitter Input Parameters

W0810

Measured variable:

Temperature from the built-in sensor

Range:

(-30 to +60) °C

Accuracy:

± 0.4 °C

Response time:

t₉₀ < 10 min (temperature change 20 °C, air flow approx. 1 m/s)

Resolution:

0.1 °C

Recommended calibration interval:

2 years

W0811**Measured variable:**

1 x temperature from the COMET Pt1000/E external probe

Range:

(-90 to +260) °C, sensor Pt1000/3850 ppm

Input accuracy (without probes):

±0.2 °C in range -90 to +100 °C

±0.2 % of measured value in range +100 to +260 °C

Accuracy of the instrument with attached probe is defined by the above input accuracy and the accuracy of the probe used.

Connection method:

Two-wire connection with compensation of errors caused by resistance wire cable. The probe is terminated by a 3-pin M8 ELKA 3008V connector. The connection method is shown in Appendix 1. Recommended length of probes Pt1000/E is up to 15 m, do not exceed a length of 30 m.

Response time:

is determined by the response time of the used probe.

Resolution:

0.1 °C

Recommended calibration interval:

2 years

W0832**Measured variable:**

1 x internal temperature (input No. 3)

2 x temperature from external probe COMET Pt1000/E

Range:

Temperature internal: (30 až +60) °C
Temperature external: (-200 až +260) °C,
sensor Pt1000/3850 ppm

Accuracy of internal sensor:

± 0.4 °C

Accuracy inputs (without probes):

±0,2 °C in range -200 až +100 °C

±0.2 % of measured value in range +100 až +260 °C

Accuracy of the instrument with attached probe is defined by the above input accuracy and the accuracy of the probe used.

Connection method:

Two-wire connection with compensation of errors caused by resistance wire cable. The probe is terminated by a 3-pin M8 ELKA 3008V connector. The connection method is shown in Appendix 1. Recommended length of probes Pt1000/E is up to 15 m, do not exceed a length of 30 m.

Response time of internal sensor:

t₉₀ < 10 min (teplotní skok 20 °C, proudění vzduchu cca 1 m/s)

Response time of external probe:

is determined by the response time of the used probe

Resolution:

0.1 °C

Recommended calibration interval:

2 years

W0850

Measured variables:

1x temperature from the built-in sensor
2x binary input to connect voltage or voltage-free contact (open collector transistor).

Range:

temperature: (-30 to +60) °C

Accuracy:

± 0.4 °C

Response time:

t₉₀ < 10 min (temperature change 20 °C, air flow approx. 1 m/s)

Resolution:

0.1 °C

Binary inputs:

Both a voltage and a non-voltage contact can be connected to the binary input. **Before connecting** the input signals, it is necessary to configure the device so that the binary inputs either sense the state of a voltage-free contact or evaluate the level of the connected voltage.

Input voltage level:

Input voltage level "L":	< 1.5 V
Input voltage level "H":	> 4.0 V
Input current:	50 µA (U _i = 5 V)
	0.8 mA (U _i = 12V)
	2.0 mA (U _i = 24 V)
	2.5 mA (U _i = 30 V)
Minimum input voltage:	0 V
Maximum input voltage:	+30 V DC

Parameters of voltage-free contact:

Contact resistance for "closed" state:	< 10 kΩ
Contact resistance for "open" state:	> 250 kΩ
Voltage at open contact:	cca 3 V

Minimum duration of one state or level for capturing it:

Alarm function off:	10 min
Alarm function on:	1s

Connection method:

4 wired shielded cable with length of 1 m

In case of cable extension is the maximum cable length 15 m. It is recommended to use shielded cables.

Inputs are not galvanically separated from each other!

See Appendix 4 for input wiring details.

Recommended calibration interval:

2 years

W3810**Measured variables:**

Temperature and relative humidity from internal sensor.

Dew point temperature calculated from measured temperature and relative humidity.

Range:

Temperature: (-30 to +60) °C

Relative humidity: (0 to 100) %RH without permanent condensation

Dew point temperature: -60 to +60 °C

Accuracy:

Temperature: ± 0.4 °C

Relative humidity:

- sensor accuracy ± 1.8 %RV

(at 23 °C in the range of 0 to 90 %RV)

- hysteresis $< \pm 1$ %RV

- non-linearity $< \pm 1$ %RV

- temperature error: 0.05 % RH/°C (0 °C to +60 °C)

Dew point temperature: ± 1.5 °C at ambient temperature $T < 25$ °C a RV > 30 %, details see graphs in Appendix 3

Response time (air flow approx. 1 m/s):

Temperature: $t_{90} < 8$ min (temperature change 20 °C)

Relative humidity: $t_{90} < 50$ s (humidity change 30 %RV, constant temperature)

Resolution:

Temperature including dew point temperature: 0.1 °C

Relative humidity: 0.1 %.

Recommended calibration interval:

1 year

W3811

Measured variables:

The temperature and relative humidity measured by the Digi/E series external probe. Dew point temperature calculated from the measured temperature and relative humidity.

Range, accuracy and response time:

According to the connected Digi/E series probe

Connection method:

Digi/E series probe. The probe is terminated by a 4-pin M8 ELKA 4008V connector. The method of connection is shown in Appendix 2. The length of the Digi/E probe cable must not exceed 15 m.

Resolution:

Temperature including dew point temperature: 0.1 °C

Relative humidity: 0.1 %.

Recommended calibration interval:

1 year

W7810

Measured variables:

Temperature, relative humidity and atmospheric pressure from the built-in sensor.

Dew point temperature calculated from measured temperature and relative humidity.

Range:

Temperature: (-30 to +60) °C

Relative humidity: (0 to 100) % RH without permanent condensation

Dew point temperature: -60 to +60 °C

Atmospheric pressure: 600 to 1100 hPa

Accuracy:

Temperature: ± 0.4 °C

Relative humidity:

- sensor accuracy ± 1.8 %RV

- (at 23 °C in the range of 0 to 90 %RV)

- hysteresis < ±1 %RV

- non-linearity < ±1 %RV

- temperature error: 0.05 % RH/°C (0 °C to +60 °C)

Dew point temperature: ± 1.5 °C at ambient temperature T < 25 °C a RV > 30 %, details see graphs in Appendix 3

Atmospheric pressure: ± 1.3 hPa at 23 °C

Response time (air flow approx. 1 m/s):

Temperature: t₉₀ < 8 min (temperature change 20 °C)

Relative humidity: t₉₀ < 50 s (humidity change 30 %RV, constant temperature)

Resolution:

Temperature including dew point temperature: 0.1 °C

Relative humidity: 0.1 %.

Atmospheric pressure: 0.1 hPa

Recommended calibration interval:

1 year

W7811

Measured variable:

The temperature and relative humidity measured by the Digi/E series external probe. Dew point

temperature calculated from the measured temperature and relative humidity. Atmospheric pressure is measured by an internal sensor.

Range, accuracy and response time for measuring temperature, relative humidity and dew point temperature:

According to the connected Digi/E series probe

Range of atmospheric pressure measurement:

600 to 1100 hPa

Accuracy of atmospheric pressure measurement:

± 1.3 hPa at 23 °C

Connection method:

Digi/E series probe. The probe is terminated by a 4-pin M8 ELKA 4008V connector. The method of connection is shown in Appendix 2. The length of the Digi/E probe cable must not exceed 15 m.

Resolution:

Temperature including dew point temperature: 0.1 °C

Relative humidity: 0.1 % RH

Atmospheric pressure: 0.1 hPa

Recommended calibration interval:

1 year

Dimensional drawings

W0810

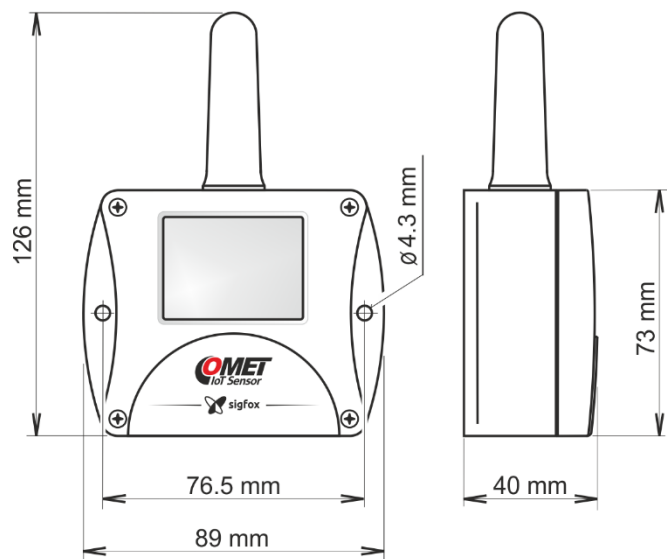

W0811
W3811
W7811

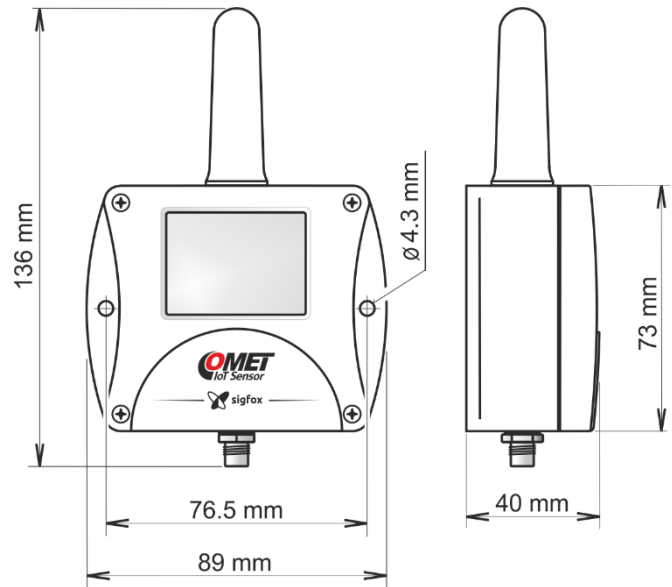

W0832

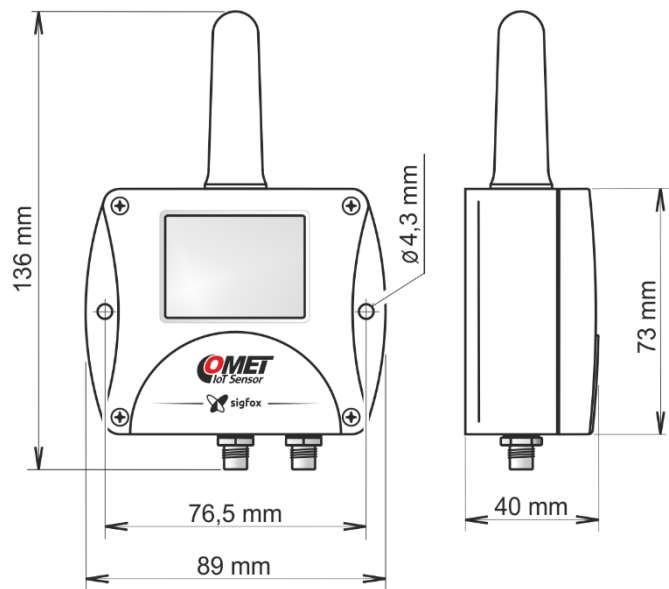

W3810
W7810

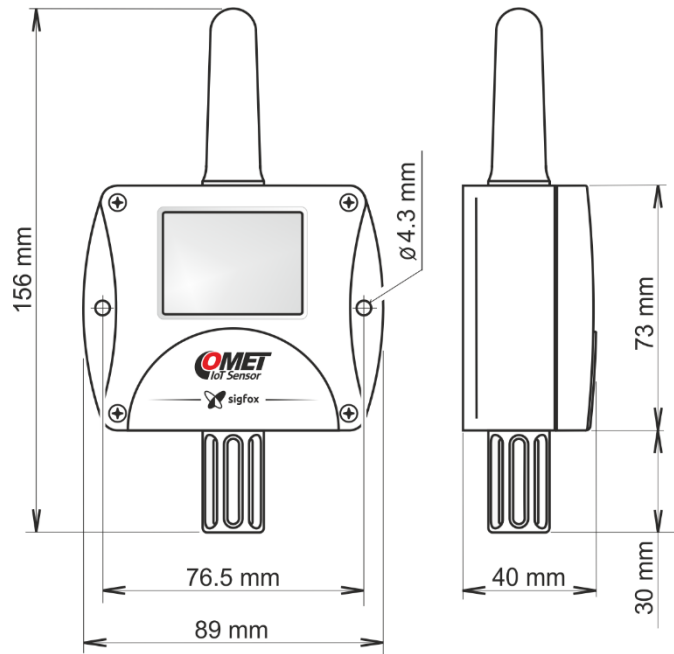

W0850

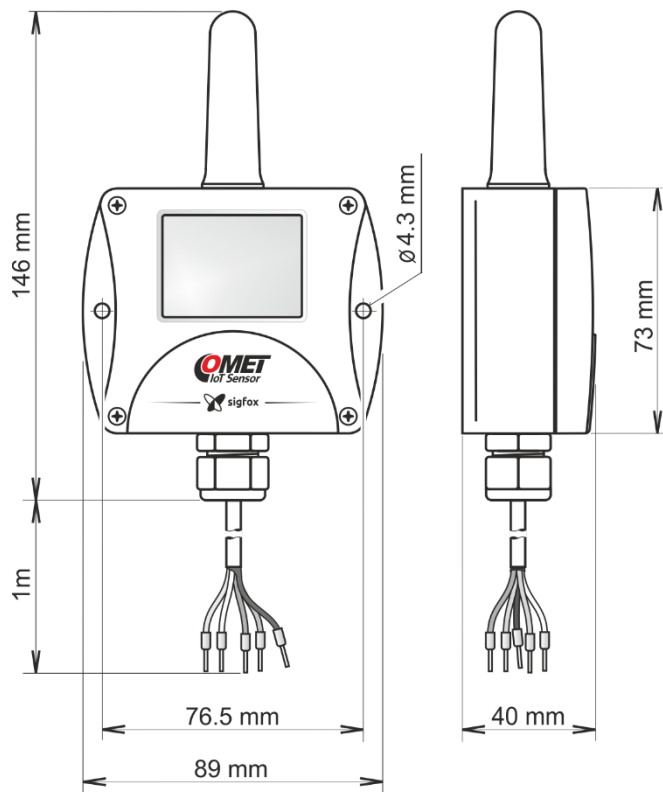

Declaration of Conformity

The transmitter complies with the requirements of Directive 2014/35 / EU. The original Declaration of Conformity can be found at www.cometsystem.com.

Appendices

Appendix 1: Connecting the Pt1000/E probe connector

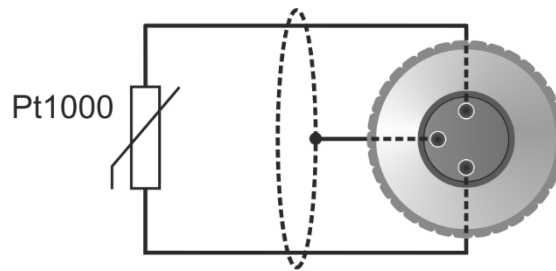

Appendix 2: Connection of the Digi/E probe connector

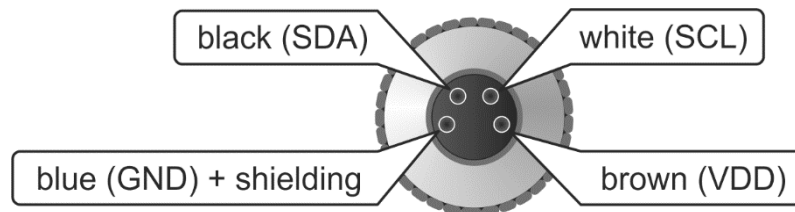

Appendix 3: Accuracy of dewpoint temperature measurement

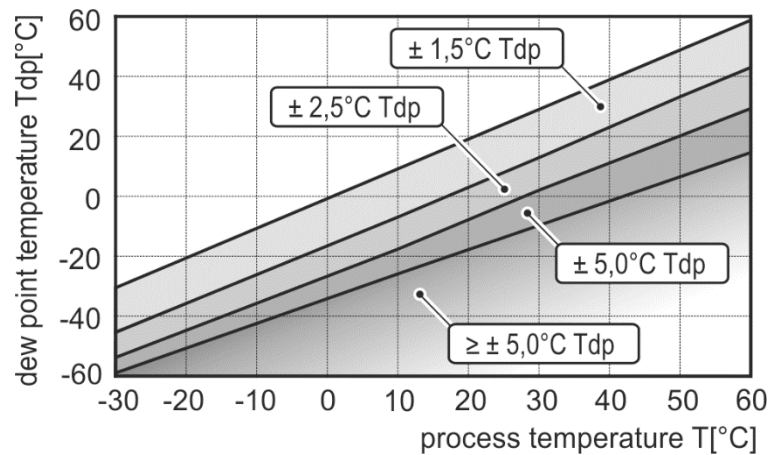

Appendix 4: W0850 input wiring details

